



# Securely Compressed Extensive Text Messages: The Interactive Mobile Learning for Distance Education in the COVID – 19 Pandemic

H. K. Salinda Premadasa <sup>a\*</sup>

<sup>a</sup> Centre for Computer Studies, Sabaragamuwa University of Sri Lanka, Sri Lanka.

## **Author's contribution**

*The sole author designed, analysed, interpreted and prepared the manuscript.*

## **Article Information**

DOI: 10.9734/AJRCOS/2023/v16i3355

## **Open Peer Review History:**

This journal follows the Advanced Open Peer Review policy. Identity of the Reviewers, Editor(s) and additional Reviewers, peer review comments, different versions of the manuscript, comments of the editors, etc are available here: <https://www.sdiarticle5.com/review-history/102816>

**Original Research Article**

**Received: 18/05/2023**

**Accepted: 21/07/2023**

**Published: 31/07/2023**

## **ABSTRACT**

The COVID-19 pandemic has made a massive impact on the higher education system in the present globe. Universities had to close abruptly due to keeping up social distancing to prevent the spread of the Coronavirus in the world community. As a result, the existing face-to-face education style is rapidly shifting to distance education environment through the mobile technology. Here, an extensive text messages, one of the most popular applications, make a significant contribution on higher education. However, in this scenario, the single text message is not sufficient in various academic activities such as sending short lecture summaries, feedbacks, assessment timetables, useful web links, detailed news, notices, and examination results to achieve educational prospects to obtain better results in distance education. Moreover, standard SMSs do not provide message confidentiality when sending sensitive data, such as examination results. Here, we propose a novel technique for extensive text message compression to create an interactive mobile learning environment for distance education in the present pandemic situation. This proposed secure mechanism provides message confidentiality, authenticity, and integrity with cryptographic

\*Corresponding author: E-mail: [salinda@ccs.sab.ac.lk](mailto:salinda@ccs.sab.ac.lk);

protection. Initially, the teacher inserts academic-related information as an extensive text message. The extensive text message is then compressed and secured with the initialization vector and the secret key in the proposed mechanism. Finally, the securely compressed single text message transmits to students who will decompress it into its original form on their mobile devices. The result shows that students' extrinsic motivation in their distance learning environment effectively and efficiently in the COVID-19 pandemic.

*Keywords: SMS; secure text compression; distance education; mobile technology.*

## 1. INTRODUCTION

Distance education has become a well-accepted, essential, and rapidly growing field in the present globe. Also, it plays a vital role as an alternative mechanism for conventional education to offering undergraduate and post-graduate degree programs [1]. However, the inability to maintain regular contact with the teacher and their peers for academic purposes, failure to get prompt feedback from the teacher that some learners prefer, and the inability to use the library are significant problems identified in distance education. As a result, emotional feelings, such as loneliness or isolation, may arise in their minds [2]. Therefore, most institutions involved in distance education are interested in maintaining maximum academic and personal interactions between teacher-student and student-student to mitigate these problems. In the meantime, the researchers and scientists have been interested in finding an appropriate technology that can be used for distance education to facilitate a better learning environment [3].

Mobile learning is a form of education that provides the learner opportunities to access their learning materials using handheld devices through a wireless network and the Internet in the ubiquitous (anytime and anywhere) nature [4]. Furthermore, mobile learning emphasizes that learners can connect to learn from anywhere and at any time and also integrate learning with life and work. In that sense, it is clear that the students should no longer see education as a separate activity that should take place in a school, university, or other educational institution [5]. Mobile learning is an excellent fit for distance education because it can meet the needs of the mobile workforce's unique work style and make up a large number of potential distance learners. Provision of course contents, feedback, weblinks, administrative services, student-student, student-teacher interactivity, and institutional interactivity (such as the library) are major supportive dimensions of mobile learning for distance education [6].

Short Messaging Service (SMS) has become one of the most popular mobile learning techniques throughout the last decade. The teachers are continuously engaged in various academic activities to organize a better learning environment in distance education. Supporting them in such endeavours will make the sustainability of student's learning ability [7]. However, the single text message is not sufficient in various academic activities because sometimes teachers require to send short lecture summaries, feedbacks, assessment timetables, weblinks, and detailed news to achieve educational prospects to obtain better results before scheduled classes in distance education. Moreover, the existing SMS does not provide a proper security mechanism because security is not the priority for mobile devices in SMS transmission [8].

The message automatically split into a series of concatenated messages when sending a long text message containing more than 160 characters in mobile communication. The mobile device which received the concatenated messages is then responsible for merging them into its original form (long text message). Due to this long text message concatenation, the sender must pay for the number of split messages under the service providers' rules and regulations [9]. This character limitation of a single text message (160 characters) has resulted in many socio-economic problems in the mobile learning environment. If it is required to send more than 160 characters, it would not be cost-effective as it splits into several messages. In such cases, the mobile users may try to pack the information into a single standard message by abbreviating words or deleting words where does not affect the meaning. Perhaps, such alternative solutions may be helpful to override socio-economic problems [10]. However, the solid compression and decompression mechanism with secure transmission are preferred in the SMS technology to obtain a better mobile learning environment in distance education.

Hence, this study attempts to ascertain university students' academic performance engaged in distance education who use SMS technology in the mobile learning environment in a user-friendly, secure, technologically and economically feasible manner. Here, we use the Message Digest-5, Advanced Encryption Standard (AES), Initial Vector ( $IV$ ), and Secret key ( $S_k$ ) for message compression and encryption in the proposed mechanism. The single standard text message can create by compressing an extensive text message with this proposed mechanism. At the same time, AES encryption assures against modification, eavesdropping, and man-in-the-middle attacks. This would be more generous support to mitigate the number of concatenated messages in the mobile learning environment to obtain academic activities in distance education, requiring post detailed information. Hence, this mechanism facilitates to reduce the cost of sending a massive amount of messages. Moreover, it provides a guarantee for sensitive data transmission using message confidentiality and integrity.

The study evaluates the students' acceptance of the proposed mechanism. It evaluates user-friendliness, technical feasibility, educational impact, and benefits of the proposed system to ascertain the academic performance in the distance education environment. We applied the Likert Mean to evaluate students' acceptance of the proposed mechanism. Also used pre- and post-usage survey analysis and paired sample t-Test (parametric) to compare pre-usage and post-usage conditions; user-friendliness, technical feasibility, and educational impact of the proposed mechanism for distance education.

Here we organize the rest of the paper as follows. Section 2 discusses the relevant previous literature, Section 3 presents the theoretical background, Section 4 describes the proposed system functionality, Section 5 elaborates the Material and Methods, Section 6 contains results and discussion of the undertaken study, Section 7 encompasses the conclusion followed by the theoretical and practical implication of the undertaken research.

## 2. LITERATURE REVIEW

Ziden et al. [11] have shown that learning via SMS is an effective method that facilitates learning and is useful as a reminder in distance education. Except for a few issues mentioned,

respondents concluded that the SMS learning experience was excellent and valuable. They are generally satisfied with their system. The study also revealed that the potential of SMS learning as a useful, innovative, and pedagogical paradigm in distance education. Further, they studied the students' participation in SMS use for distance educational activities with their lecturers by investigating students' personal beliefs and perceptions. Ismail and his research colleagues [12] found that in his research, SMS technology can use to encourage inquisitive learning skill among distance learners. This study highlighted prominently, regardless of technical disputes, SMS could still carry out positive impacts in the mobile learning of distance education. According the digital divide, the internet and mobile network access in middle- and low-income countries shows clear differences. Governments in those countries can immediately support this by educating teachers about their own simple grassroots platforms such as ED-Tech for their own education. In the present COVID-19 pandemic, which has had to deviate from the classroom teaching pattern, and in the context of poor or no internet connection, educational television channels, and radio channels can be integrated with SMSs to create effective communication between educators and students [13].

The one-way SMS communication mechanism was initiated among distance learners by Ramli et al. [14] to examine the students' acceptance and readiness towards mobile learning. Students can only receive SMS but no permission to send a reply SMS to the teacher with this mechanism. The teacher can send lecture summaries, terms, equations, and problem-solving methods related to the subject matter using one-way SMS communication for distance learners. Later on, such an SMS-based learning system supported two-way communication among distance learners and lecturers in their academic activities. Premadasa and Meegama [15] could create a two-way text messaging system enclosing concealed data in the message body. They used the SMS user data header (UDH) to include a part of the incoming message in the reply message. That mechanism created an interactive mobile learning environment to obtain their assignment activities and grading process. Ziden and Rahman [16] revealed that the quiz via the SMS system could use to evaluate teaching and learning progress at any time anywhere. This system offered further the quiz-based assessment method of various courses and

continuous assessments conducted by experts to students. According to Belawati et al. [17] the usage of SMS can categorize as academic, extra-curricular, and administrative, depending on the purpose used. Therefore, the SMS would be supported to overcome the accessibility and interactivity problems in distance education as well as beneficial for institutional formative activities.

While standard single SMSs have been using for distance education for a long time in this way, Premadasa and Meegama [18] introduced a novel concatenated SMS system for sending long text messages to engage both educational and administrative activities through an Internet-enabled mobile device. However, this would not be a cost-benefit mechanism because it is essential to split the extensive text message into several messages as concatenated for a single recipient per activity in the academic or administrative environment.

Gligoric et al. [19] introduced a secure text compression mechanism with the GZIP compression algorithm. The results revealed that the compressed payload was 13.5% smaller than the original payload with their mechanism. The SMS ZIPPER compression mechanism of Mohd and Wong [20] provided a 40% compression efficiency for SMS communication using a dictionary-based method. According to Bhanarkar and Jha [21], the Intelligent Dictionary Based Encoding (IDBE) mechanism facilitates text message compression in another way by using the semantic dictionary included in the mobile device. With this mechanism, the English words enclosed in the text message compared first. These words are then replaced from the semantic dictionary to utilize phone memory in SMS communication. Also, Affandi et al. (2011) used the Huffman table to compress and decompress the message contents. They achieved a considerable compression ratio (29%) with their SMS communication mechanism when sending out both binary and multimedia messages. They tested their message compression application for upper and lower case texts separately to determine the message compression ratio.

With mobile technology's rapid development globally, conducting commercial activities through mobile devices has become more popular. The SMS service is making an enormous contribution to the transmission of sensitive data. However, since SMS

communication does not guarantee the integrity and confidentiality of the message, a high security and reliability level in the transmission of sensitive data cannot be expected. Prasad et al. [22] introduced an identity-based cryptographic algorithm for activating a secure SMS channel without using high memory space on mobile devices to overcome this problem to some extent. Further, Boja et al. [23] also discovered an asymmetric encryption scheme that can encrypt text messages' content for making a secure channel with a minimal impact of the device performance.

Recent literature reviews have shown that using standard single SMSs in different ways for distance education and some compression and encryption techniques applied for long SMSs. But, there is a lack of research findings regarding secure and cost-effective compression techniques on extensive text messages for distance education. Therefore, we proposed a secure extensive message compression mechanism that can be integrated into a Learning Management System (LMS) to fill the research gap. Further, this mechanism facilitates minimizing the associated cost by sending concatenated messages by the institutes in the distance learning environment.

### 3. THEORETICAL FRAMEWORK

Data compression can be used to make more effective use of existing bandwidth, thereby reducing communication costs. This would be a great opportunity in the distance learning environment when sending detailed academic and administrative information. The Lossy algorithms and Lossless algorithms are two major categories in the data compression arena. The Lossy compression algorithms can only reconstruct an approximate amount of data of the original data file in the decompression process. Therefore, this technique can be used for non-sensitive image, audio, and video compression if the compression lost is often undetectable or at least acceptable. But the Lossless compression algorithms can reconstruct the original message precisely in the decompression process. They can use sensitive images such as medical or biological images for all kinds of texts where recovery needs to be precise [24]. The message encryption can be integrated into the message compression process to provide an added value. Then, it would be supported to transmit sensitive data in the distance learning environment. However, the encryption can be retained only the

message confidentiality and need to find other techniques to provide message integrity and authenticity for the SMS communication [25]. Many factors, such as security, speed, and memory consumption, must be considered when choosing an encryption technique. Also, combining message compression and encryption for SMS communication is a challenging task [26].

The Initialization Vector (*IV*) is a randomly generated number for encrypting data that is used only once per session with a secret key (*Sk*). Furthermore, this *IV* supports preventing recurrence during the SMS encryption process. Therefore, the intruders are impossible to discover the encryption pattern to decrypt the cipher-text while in the message delivery. Since *IV* changes randomly per session and *Sk* functions as a private key, *IV* does not need to be considered a secret (William, 2003). But, it is essential to keep up the *Sk* as confidential from unauthorized users.

The Advanced Encryption Standard (AES) is a symmetric block cipher algorithm used to encrypt and decrypt information. In the encryption process, this algorithm can convert a plain text (maybe a text message) into an unintelligible format called cipher-text and restore it into its original form in the decryption process. The AES algorithm uses 128, 192, and 256 bits cryptographic keys for encrypting and decrypting operations while using fixed-size 128 bits of data blocks [27]. But Rijndael symmetric key encryption algorithm supports any cryptographic key sizes and block sizes in a multiplication of 32 bits, including a minimum of 128 bits and a maximum of 256 bits. Most of the libraries in a JAVA platform are supported 128 bits cryptographic keys for message encryption. Hence, the Rijndael-128 bits would be the most suitable algorithm for text message encryption and decryption in a JAVA environment [28]. Also, the Rijndael 128-bits is the most appropriate algorithm to be used in the Cipher Feed Back (CFB) mode for encrypting text messages with the combination of *IV* and *S<sub>k</sub>* in a PHP environment [29,30,31].

The Message Digest-5 (MD5) is a popular cryptographic hashing algorithm that provides message authentication and integrity. A text message containing an arbitrary number of characters can be entered as input to the

algorithm. It will then generate 128 bits message digest by setting up four blocks (each containing 32 bits) as an output. This algorithm's uniqueness is that utterly different message digest outputs can obtain only by changing a single character of two similar messages. Therefore, MD5 can identify as a robust hash algorithm that can be precisely detecting minor changes, which is very important in secure message compression [32,33].

Here, the MD5 cryptographic hashing algorithm with the Cipher Feed Back (CFB) mode is used in the proposed mechanism to perform extensive message compression. Furthermore, the secret key (*Sk*) is combined with the MD5 hash algorithm to provide a 32-character fixed-length hashed value to avoid a dictionary attack in MD5 vulnerabilities. Then, the randomly generated initialization vector is encrypted by using this hashed value to perform cryptographic protection. An arbitrary number of characters in the extensive text message (plain text) combine with the encrypted value using the XOR condition. The cipher-text obtains a 32-character fixed-length as a result. Hereafter, this fixed-length cipher-text is inserted into the OUTBOX table in the SMS database integrated into an LMS server as a standard single text message. The theoretical background of this encryption and compression of plain-text (Fig. 1-a) and the decryption of cipher-text (Fig. 1-b) can be described as follows.

Further, the message compression with the encryption and decryption algorithms of the proposed technique can be represented as follows:

In the encryption stage,

$$\begin{aligned}
 C_0 &= IV \\
 K_i &= H_{MD5}(S_k) [C_{(i-1)}]; \text{ for } i \geq 1 \\
 C_i &= K_i \oplus P_i; \text{ for } i \geq 1 \dots\dots\dots (1)
 \end{aligned}$$

In the decryption stage,

$$\begin{aligned}
 C_0 &= IV \\
 K_i &= H_{MD5}(S_k) [C_{(i-1)}]; \text{ for } i \geq 1 \\
 P_i &= K_i \oplus C_i; \text{ for } i \geq 1 \dots\dots\dots (2)
 \end{aligned}$$

Where  $C_i$  = cipher text,  $P_i$  = plain-text,  $IV$  = initialization vector,  $\oplus$  = XOR operator,  $S_k$  = secret key and  $H_{MD5}$  = hashing algorithm for the entire operation.

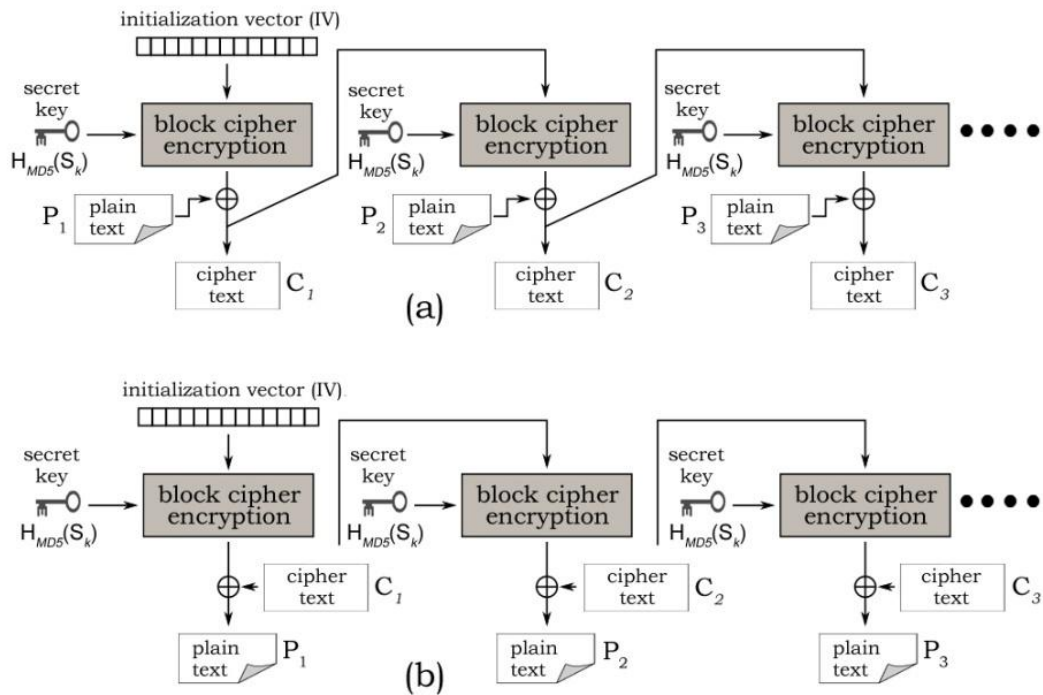

**Fig. 1. Message compression with encryption (a) and decryption (b) using initialization vector and secret key in CFB mode [34]**

The proposed mechanism allows us to compress long text messages securely. It would be an excellent opportunity to reduce the costs involved in sending out concatenated messages in a distance learning environment. PHP and JAVA languages are used in the implementation phase on the server-side (LMS server) and client-side (mobile device), respectively. In contrast, the operating system of the mobile device is Android. The Initialization Vector (IV) is randomly generated per each session and can be sent with the text message (cipher-text) while the secret key ( $S_k$ ) is exchanged between a sender and a recipient securely.

#### 4. SYSTEM FUNCTION AND ARCHITECTURE

After log on to the relevant course module in the LMS, the proposed mechanism allows a teacher to create extensive text messages to send short lecture summaries, feedbacks, assessment timetables, useful weblinks, detailed news and notices as well as confidential data such as examination results containing an arbitrary number of characters via a mobile browser interface through an Internet-enabled mobile device (As shown in Fig. 2).

When a teacher attempts to insert an extensive text (plain text), the front-end software of the

proposed mechanism generates cypher-text using the extensive text with the secret key ( $S_k$ ; can be recognised as the symmetric key) and the initialization vector (IV). This  $S_k$  should contain a combination of alphanumeric characters and punctuation symbols with more than 8 values and also the teacher is free to choose this secret key. Then this cipher-text inserts into a database with the IV. Hereafter, the SMS Daemon periodically checks the OUTBOX in the database and sends the stored messages to the GSM modem via the SMS gateway. The modem then uses the "AT" command to send cyphertext to the student via the SMS Service Center (SMSC) of the mobile service provider as a standard single SMS. The SMS INBOX containing the student's mobile device receives the cipher-text and the IV as a standard single text message. The secret key ( $S_k$ ) will be requested by the mobile device's front-end software to decompress and open the message. Therefore, after the encrypted text message is sent, the secret key must be handed over to the distance learner via another text message or during a classroom lecture session as needed to maintain the authenticity of the message. After inserting the  $S_k$ , by the learner, the mobile device's front-end software generates the original message using the decryption process of the proposed mechanism.

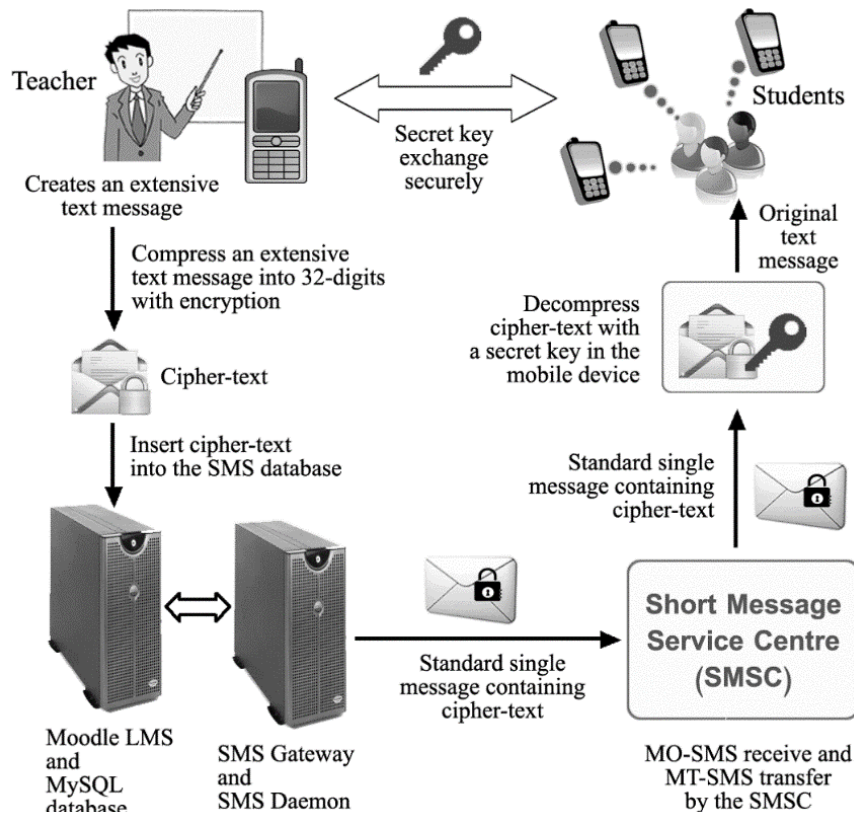

Fig. 2. System function and topology



Fig. 3. Front-end interfaces of the proposed system of the mobile phone with, (a) teacher inserts extensive text message with a secret key, (b) student receives the message and inserts secret-key, (c) student views the original message

After the lecturer login to the relevant course module in the LMS, the proposed mechanism's front-end design provides a specific option for selecting the phone numbers of single or multiple recipients to send messages. It also can limit the number of messages a teacher can send in a given time to alleviate the excessive use of text messages. The system log file can also be used by the teacher to monitor the message delivery information such as the number of messages, delivery time, receiving phone numbers in each text message. Fig. 3(a) illustrates the implemented front design of the teacher-side, using PHP, XHTML-Mobile Profile, and CSS. Also, Fig. 3(b) and 3(c) illustrate the implemented front designs of the student-side using JAVA on the Android environment.

## 5. MATERIALS AND METHODS

The research was undertaken between October 2020 and July 2021 and carried out on the distance learner group registered in the Centre for Open and Distance learning (CODL), Sabaragamuwa University of Sri Lanka. The analysis was carried out using two samples where engaging in distance education as science (50 students) and non-science (50 students) separately at first and, finally, as an overall sample (100 students) and also divided into preliminary investigation and advanced analysis. A score value (-10=strongly disagreed, -5=disagreed, 0=neutral, 5=agreed, 10=strongly

agreed) was assigned to each option in the list of answers at the pre and post-usage survey. The following questionnaire (in Table 1) was used to collect data through the Google Form for evaluating the user-friendliness, technical feasibility, educational impact, and benefits of the proposed system.

The data set was followed by a normal distribution, as well as data amount was exceeded 30. Hence the parametric test was used in advance to compare pre-usage and post-usage conditions under the 0.05 significant level.

We applied Likert Mean to evaluate students' acceptance of the proposed mechanism and used pre- and post-usage survey analysis and paired sample t-Test (parametric) to compare pre-usage and post-usage conditions to evaluate user-friendliness, technical feasibility, and educational impact of the proposed mechanism for distance education. Likert Mean was calculated for the entire data set, which was collected under post-survey for the preliminary investigation. The Likert Mean (LM) describes the following interpretations on score values;  $LM < -5$  describes the proposed system is strongly rejected,  $-5 < LM < 0$  describes the proposed method is normally rejected,  $LM = 0$  describes the proposed method is impartial,  $0 < LM < 5$  describes the proposed system is normally accepted,  $5 < LM$  illustrates the proposed system strongly accepted by the university education community.

**Table 1. Pre and Post-survey questionnaire (The pre-survey questionnaire was used for the traditional method, and the post-survey questionnaire was used for the proposed method.)**

Question number	User Friendliness (UF)	Technical Feasibility (TF)	Educational Impact (EI)
Q1	I can effectively and efficiently complete my learning activities using this method (Q1_UF)	I can handle the technical-end process in this method neatly (Q1_TF)	I can gain the preeminent learning outcome from students before the scheduled classes using this method (Q1_EI)
Q2	I believe I became productive quickly using this method (Q2_UF)	I can receive assignment grades/other information without any interruptions or delays with this method (Q2_TF)	This method makes me interactive and encourages me for distance learning at any-time, anywhere (Q2_EI)
Q3	The user interfaces of this method are pleasant (Q3_UF)	I can use this method with any network and any device (Q3_TF)	Brief lecture summaries, assessment schedules or feedback, detailed news and notices to students as well as confidential data such as exam results can receive without attending the class (Q3_EI)



## 6. RESULTS AND DISCUSSION

Providing comprehensive message compression with cryptographic protection and the ability to integrate this mechanism with widely used LMS such as Moodle for distance education also lead to the use of this emerging technology. Once a lecturer logs in to the particular course module in Moodle LMS, he or she can create an extensive text message and send including short lecture summaries, feedbacks, assessment timetables, useful weblinks, and detailed news and notices as well as confidential data such as examination results to distance learners who enrolled the relevant course module at once through this mechanism.

Initially, we evaluate the performance of the compression mechanism using different types of mobile devices having different RAM sizes and processing speeds in the Android environment. In this process, we use the Standard English text files taken from the Canterbury Corpus [35]. Fig. 4 depicts the time variations of message compression while inserting the files obtained from the Canterbury Corpus files into the proposed mechanism.

The results show that performance of the algorithm varies according to the memory size and the processing power of the mobile device. Also the, the performance is dependent on the file size (number of characters) of the Canterbury Corpus. For instance, to compress a file having only a single character (best case) takes the same amount of time as the other files having larger number of characters. In order to evaluate such best case performance, we used our own text files containing 2 to 10 characters. Here also, we evaluate the performance of the compression mechanism using different types of mobile devices having different RAM sizes and processing speeds in the Android environment. Average compression time for this evaluation result in 3.20 seconds (for 2chars), 3.21 seconds (for 3chars), 3.20 seconds (for 4chars), 3.20 seconds (for 5chars), 3.20 seconds (for 6chars), 3.22 seconds (for 7chars), 3.20 seconds (for 8chars), 3.20 seconds (for 9chars) and 3.21 seconds (for 10chars). The average compression time of the different RAM sizes and processing speeds for the file "a.txt" in the Canterbury Corpus (which is containing a single character) is also 3.20 seconds. On the other hand, highest average compression time 3.46 seconds is for "alice29.txt", "book2.txt" and "paper2.txt" files where containing 1044, 1016 and 1020

characters respectively in the Canterbury Corpus. This result indicates no significant reduction in time to process such short text as we would have expected theoretically.

However, the result shows that the file size (character length of the message) could be increased only up to a certain limit without generating a "no response" or "taking too much time" message. But this limit does not represent an exact value. The result shows that, when we insert over 1800 characters into both mobile phones where containing 290 MB (830 MHz Processor) and 512 MB (1 GHz Processor) RAM sizes, the compression mechanism does not function well and give the message "no response". But in the mobile phones where containing 768 MB (1 GHz Processor) and 1GB (1.2 GHz Processor) RAM sizes, the compression mechanism function well up to 1830 characters. However, this is not a significant variation when considering the RAM size and the processing power of the devices where we tested. Hence, the result conclude that nearly 1800 characters will be acceptable in any kind of mobile devices in the proposed compression mechanism with better performance.

Further, distance learners' feedback is a vital factor in evaluating the user-friendliness, technical feasibility, educational efficiency of the proposed system in distance education. Two groups of distance learners, from sciences and non-sciences, familiar with traditional paper-based and LMS environments, were asked to fill out two questionnaires within a realistic time frame according to the proposed system's pre and post-usage. Initially, the traditional learning environment is prepared for both teachers and students to obtain their academic activities. Short lecture summaries, feedback, assessment timetables, useful weblinks, and detailed news and notices and confidential data such as examination results were prepared by the teacher in the form of printed versions and electronic versions. The printed versions were handed over among distance learners while electronic versions were uploaded on the LMS. At first, a pre-usage questionnaire was given to them after completing this traditional practice with the teacher. Subsequently, the teacher was given an introduction about the proposed system that posted the same information to the same batch of distance learners via a text message. Then post-questionnaire was given to the same batch and asked them to fill it according to the proposed system.

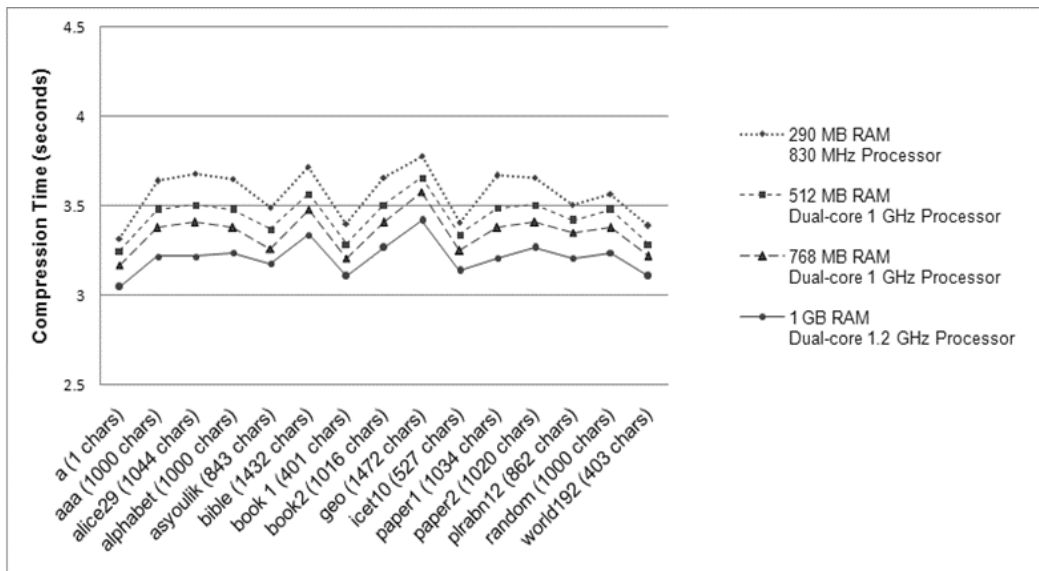

Fig. 4. Time variation of message compression in Canterbury Corpus files

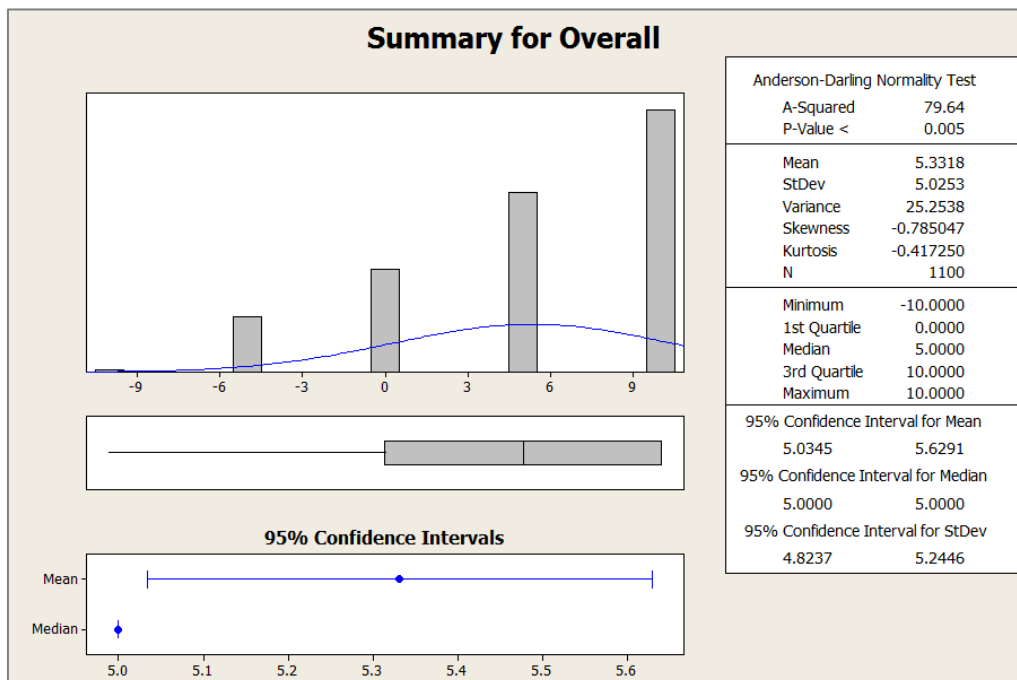

Fig. 5. Preliminary analysis of overall data

The results (described in Fig. 5) revealed that the data set is normally distributed ( $p < 0.005$ ). The overall Likert Mean is 5.3318, and this would accomplish that distance learners strongly accept the proposed system. Further, the result shows that the overall Likert Mean is in the confidence interval (5.0345, 5.6291), and therefore overall Likert Mean can be accepted under the 0.05 significant level. It was further analyzed according to the group (science or non-science) and type of the question [36-39].

### 6.1 User-Friendliness

The distance learners were asked whether they can effectively and efficiently complete their learning activities interactively using the proposed system. The responses were satisfactory, with an overall mean score of 5.15 in agreement (user-friendliness: question Q1\_UF as in Table 1). In this trial, participants from the non-science stream accounted for 4.60, while it was 5.70 for the science participants. This may

be since the former group was unfamiliar with using the mobile device when using the proposed system. However, considering the overall mean value, participants appeared to accept this mechanism as an effective and efficient mechanism for distance education.

A high mean score of 6.30 from science students indicates a satisfactory response for the productivity of ease of use rather than the non-science students who scored a mean of 4.20 for the second question (user-friendliness: question Q2\_UF as in Table 1). Science students were not so keen to participate in the traditional face-to-face interaction with the teacher as they productively adapted to the proposed mechanism. It is no secret that the proposed mechanism has thus given them a novel experience of distance learning. However, non-science students have given some uncertain responses to this question, which may be due to their familiarity with such technical aspects in education.

In the third question in the scale of user-friendliness (user-friendliness: question Q3\_UF as in Table 1), the participants were asked about user interfaces' interactivity in the proposed mechanism. A high mean score of 6.50 from science students indicates a satisfactory response to user interfaces' interactivity in the proposed mechanism, while non-science scored a mean 4.90. However, when considering an overall mean score of 5.70, the participants somewhat agreed that user interfaces' interactivity was enough to be continued their learning activities with the proposed system. Student responses under Q1\_UF, Q2\_UF, and Q3\_UF used to explore user-friendliness of the proposed system and hypothesis were set as below.

$$H_0 : \mu_{(User\ Friendly)} = 0 \text{ VS } H_0 : \mu_{(User\ Friendly)} > 0$$

The result shows that in Table 2, the p-Value=0.000<0.005; hence  $H_0$  was rejected and Mean>0; implied that students are willing to

accept the proposed system as a user-friendly system.

## 6.2 Technical Feasibility

Then the distance learners were asked whether they can handle the student-end process in the mobile device neatly. The responses were satisfactory, with an overall mean score of 5.75 in agreement (technical feasibility: question Q1\_TF as in Table 1). In this trial, participants from the science stream accounted for a mean of 6.10 while it was for the non-science 5.40 students. This result showed that all students could grasp this technological process well. This would lead mainly to the high usage of mobile phones among university students and the ability to handle it. The further discussion mentioned that this technique would be most suitable for their academic activities because they can easily adapt to the technique used in the system.

In the second question, students were asked whether they can receive assignment grades/other information with the proposed mechanism without any interruptions or delays. The science students' responses were more satisfactory, with a mean score of 6.80 in agreement (technical feasibility: question Q2\_TF as in Table 1) while non-science was with the value 5.40 of the mean score. The overall mean score value (6.10) interprets how both streamed students were confident in handling a compressed and secured text message without any interruption. Even if there were problems for a small number of students when entering a secret key, most students obtained it well.

The third question (technical feasibility: question Q3\_TF, as in Table 1) examined the viability of the mobile telephony networks and how they fit with the different types of mobile devices with the proposed mechanism. Science students responded in this regard with the mean score value of 5.50 while non-science was 4.50. The students showed a somewhat receptive response, but they also said that there were

**Table 2. Paired sample t-test results for user-friendliness**

	N	Mean	StDev	SE Mean
User-Friendliness - Post	100	5.46667	4.93593	0.28498
User-Friendliness - Pre	100	0.26667	6.56296	0.37891
Difference	100	5.20000	8.29796	0.47908

95% lower bound for mean difference: 4.40953  
 Paired T-Test of mean difference = 0 (vs > 0) : T-Value = 10.85 P-Value = 0.000

**Table 3. Paired sample t-test results for technical feasibility**

	N	Mean	StDev	SE Mean
Technical Feasibility - Post	100	5.61667	5.02865	0.29033
Technical Feasibility - Pre	100	-0.05000	6.30184	0.36384
Difference	100	5.66667	8.36393	0.48289

95% lower bound for mean difference: 4.86991  
T-Test of mean difference = 0 (vs > 0) : T-Value = 11.73 P-Value = 0.000

some minor effects during the types of communication network and the mobile device's performance. Student responses that were made under Q1\_TF, Q2\_TF, and Q3\_TF used to explore the technical feasibility of the proposed system and hypothesis were set as below.

$$H_0 : \mu_{(\text{Technical Feasibility})} = 0 \text{ VS } H_0 : \mu_{(\text{Technical Feasibility})} > 0$$

The result shows that in Table 3, the p-Value=0.000<0.005; hence  $H_0$  was rejected and Mean>0; implied that students are willing to accept the proposed system as a technically comprehensive system.

### 6.3 Educational Impact

The university spans a wide geographical area containing mountainous regions with unstable weather conditions throughout the year. Also, the university has located amid three provinces and a remote location from the country's capital. Students with very helpless and economic hardships are less likely to go to universities in urban areas. Their residences are located at faraway distances from the Sabaragamuwa University also. Hence, the students need to come a long way to the university either by bus, train, taxi, or even to attend their lectures, assignments, discussions, and many more. Furthermore, the current COVID-19 pandemic situation has contributed to creating an isolated and critical condition in the world today. This has been critically affected by the usual educational systems such as schools, universities, and other educational institutions. Hence, Sabaragamuwa University facilitates distance education by providing a better service to such students, and it is essential to analyze the impact of the proposed system on students' education.

The distance learners were asked whether they gain the preeminent learning outcome before the scheduled classes through the proposed system (educational impact: question Q1\_EI as in Table 1). Science students gave a considerable level of responses with a mean score of 5.60. The mean

score value (4.60) of non-science students shows that they are not very receptive to this regard. However, when considering an overall mean score of (5.10), the participants gained the preeminent learning outcome was somewhat enough to be continued their distance education with the proposed mechanism.

During the second question (educational impact: question Q2\_EI as in Table 1), students were asked that the proposed mechanism makes them interactive and encourages them to distance learning at any time, any-where. The great responses were obtained from science students with a high mean score of 6.40, while non-science students were 4.40. It was a significant difference and discussed further with both groups of students. Science students were intensely interested in distance learning and responded to promote this distance learning environment by using mobile phones. It was vital for them to save time because of the proposed mechanism. However, the results revealed that the non-science students were somewhat lagging in self-learning and mobile technology in their academic environment interactively. Moreover, a significant number of non-science students concluded that it was better to obtain a face-to-face discussion with the lecturers than using a proposed mechanism for certain educational matters such as group discussions.

In the third question (educational impact: question Q3\_EI as in Table 1), students were asked what academic information they can receive without attending the classes. The responses were obtained from science students with a mean score of 5.50, while non-science students were 4.60. The non-science students and the science students have shown their reactions in a way that does not change much. Both groups of students also claimed that they would not solely use this proposed method. They would prefer to contact the lecturers at least twice a month while using the proposed mechanism. The students would like to meet twice a month for the relevant teacher to discuss the critical educational issues in a lengthy

**Table 4. Paired sample t-test results for educational impact**

	<b>N</b>	<b>Mean</b>	<b>StDev</b>	<b>SE Mean</b>
Educational Impact - Post	100	5.11667	5.00865	0.29033
Educational Impact - Pre	100	-0.05000	6.30144	0.36384
Difference	100	5.16667	8.26393	0.48289

95% lower bound for mean difference: 4.86991  
T-Test of mean difference = 0 (vs > 0) : T-Value = 11.73 P-Value = 0.000

manner. In further discussion, they said that the way the teacher met, they could do certain things that could not be achieved by the proposed mechanism. After that, they also suggested that they would obtain their learning activities from the proposed mechanism remotely. Student responses that were made under Q1\_EI, Q2\_EI, and Q3\_EI used to explore the educational impact of the proposed system and the hypothesis were set below.

$$H_0 : \mu_{\text{(Educational Impact)}} = 0 \text{ VS } H_0 : \mu_{\text{(Educational Impact)}} > 0$$

The result shows that in Table 4, the p-Value=0.000<0.005; hence  $H_0$  was rejected and Mean>0; implied, further the proposed mechanism was more appropriate than the predominantly used traditional mechanisms and that it was confirmed to them when using the proposed mechanism.

In overall, when considering the standard deviation, the post-survey results shown a difference (User friendliness – 4.93, Technical feasibility – 5.02 and Educational impact – 5.00) while pre-survey results shown similar values (User friendliness – 6.56, Technical feasibility – 6.3 and Educational impact – 6.3). Before using the system, all students were in same condition regarding to the idea of such system. However, after using the system, they were feel differently about the system properties such as user friendliness, technical feasibility and educational impact. Then the data may be deviated. Therefore, the post survey results can vary accordingly.

Finally, in further discussion, most distance learners emphasized that such a distance education system is important and timely in isolated durations, such as the recent KOVID-19 pandemic situation in the world. Further, they believed that the system enabled them to keep up their contact with the lecturers and their education at an optimal level without compromising their well-being in critical conditions.

## 7. CONCLUSION

The objective of the undertaken study is to examine the influence of securely compressed text messages for distance education and its user-friendliness, technical feasibility, and impact on their academic performance. This research study is exclusive because the outcomes conclude the use of securely compressed text messages for various academic activities such as sending short lecture summaries, feedback, assessment timetables, useful web links, detailed news, notices, and examination results have an affirmative impact on distance education. Similarly, the user-friendliness and technical feasibility of the proposed system has a significant and positive influence on the distance learners to achieve their academic activities and keep up personal contact with the lecturers in critical conditions and isolated durations such as the COVID-19 pandemic situation. The previous literature demonstrated the use of standard text messages for different types of academic activities in distance education and their educational performance influences. Later, the usage and importance of concatenated text messages in academic and administrative environments revealed and discussed such a system's economic drawbacks. At the end of the previous literature, the compression and encryption techniques on text messages and their technical performance explored. The foremost benefit of the proposed mechanism is that it reduces the message payload size into a single standard message and provides message integrity, confidentiality, and authenticity at the same time. As such, the proposed mechanism will certainly provide an ideal opportunity for entities where sending extensive text messages to a larger user base is required. The proposed mechanism can also be easily integrated into a Learning Management System (such as Moodle) to obtain various academic, extra-curricular, and administrative activities in distance education. With this integration, lecturers can use this mechanism under the same LMS authentication environment rather than using two different usernames and passwords. Further, they can

interestingly manage their LMS environment by receiving tremendous support from the proposed mechanism. This mechanism is exceptional because it enables distance learners to maintain personal contact with the lecturers and their education even when they do not have internet access. Thus, this research's outcomes enlighten the influence of securely compressed text messages for distance education and its user-friendliness, technical feasibility, and impact on their academic performance in universities. Hence, this research study has significant theoretical and practical implications for motivating distance education without compromising students' well-being. This study has limitations that open avenues for future research. The undertaken research study has focused on the implementation in the Android platform at the recipient's end. Hence, future work is required to apply the proposed mechanism in other mobile operating systems and services. Although the authenticity of the communication channel between the teacher and the registered learner is guaranteed, the true information contained in the decoded message can be sent by the registered learner to anyone else without interruption. That process is beyond the scope of this research and is the sole responsibility of the registered student. But, this can be identified as a problem that needs to be addressed in future research.

#### **DATA AVAILABILITY**

All the data used in the paper was collected by the author. Also the data set available with author and can be given on request.

#### **CONSENT**

As per international standard or university standard, respondents' written consent has been collected and preserved by the author(s).

#### **ETHICAL APPROVAL**

As per international standard or university standard written ethical approval has been collected and preserved by the author(s).

#### **COMPETING INTERESTS**

Author has declared that no competing interests exist.

#### **REFERENCES**

1. Kabir FS, Kadage AT. ICTs and educational development: The utilization of mobile phones in distance education in Nigeria. *Turkish Online Journal of Distance Education*. 2017;18(1):63-76.
2. Sikhangezile N, Modise MA. Social distancing, cultural and psychological effects on learners in a rural setting in Zimbabwe. *Journal of Ethnic and Cultural Studies*. 2020;7(3):200-209.
3. Sharma D. Exploring the potential of mobile learning in distance higher education: A case study of the University of Jammu, Jammu, and Kashmir; 2019.
4. Grant MM. Difficulties in defining mobile learning: Analysis, design characteristics, and implications. *Educational Technology Research and Development*. 2019;67(2): 361-388.
5. Kukulska-Hulme A. Mobile learning for quality education and social inclusion; 2010.
6. Sönmez A, Göçmez L, Uygun D, Ataizi M. A review of current studies of mobile learning. *Journal of Educational Technology and Online Learning*. 2018; 1(1):12-27.
7. Shadiev R, Hwang WY, Huang YM. Review of research on mobile language learning in authentic environments. *Computer Assisted Language Learning*. 2017;30(3-4):284-303.
8. Riaz MN, Ikram A. Development of a secure SMS application using advanced encryption standard (AES) on android platform. *IJ Mathematical Sciences and Computing*. 2018;2:34-48.
9. Ryan M. U.S. Patent No. 8,335,528. Washington, DC: U.S. Patent and Trademark Office; 2012.
10. Fatima M, Anwar S, Naveed A, Arshad W, Nawab RMA, Iqbal M, Masood A. Multilingual SMS-based author profiling: Data and methods. *Natural Language Engineering*. 2018;24(5):695-724.
11. Ziden AA, Rosli M, Gunasegaran T, Azizan SN. Perceptions and experience in mobile learning via SMS: a case study of distance education students in a Malaysian public university. *International Journal of Interactive Mobile Technologies (iJIM)*. 2017;11(1):116-132.
12. Ismail I, Azizan SN, Gunasegaran T. The Use of SMS in promoting inquisitiveness

- among distance learners. *Malaysian Journal of Distance Education*. 2019;21(1).
13. David R, Pellini A, Jordan K, Philips T. Education during the COVID-19 crisis: Opportunities and constraints of using EdTech in low-income countries. Zenodo; 2020.
  14. Ramli A, Ismail I, Idrus RM. Mobile learning via SMS among distance learners: Does learning transfer occur?. *International Journal of Interactive Mobile Technologies (IJIM)*. 2010;4(3):30-35.
  15. Premadasa HS, Meegama RGN. Two-way text messaging: An interactive mobile learning environment in higher education. *Research in Learning Technology*. 2016;24.
  16. Ziden AA, Rahman MFA. Using SMS quiz in teaching and learning. *Campus-Wide Information Systems*; 2013.
  17. Belawati T, Baggaley J, Dhanarajan G. Distance education in Asia: The PANDora guidebook; 2010.
  18. Premadasa HKS, Meegama RGN. Implementation of concatenated short messaging service in a campus environment. In 2013 8th International Conference on Computer Science & Education. 2013;207-212. IEEE.
  19. Gligoric N, Dimcic T, Drajić D, Krco S, Chu N. Application-layer security mechanism for M2M communication over SMS. In 2012 20th Telecommunications Forum (TELFOR). 2012;5-8. IEEE.
  20. Mohd A, Wong TM. Short Messaging System (SMS) compression on mobile phone–SMS zipper. *Jurnal Teknologi*. 2008;49(1):173-187.
  21. Bhanarkar P, Jha N. SMS text compression through IDBE (Intelligent Dictionary based Encoding) for Effective Mobile Storage Utilization. *IJCCT*. 2012;3(1).
  22. Prasad MSV, Prasad VM. Secure sms with identity based cryptography in mobile telecommunication networks. *International Journal of Computer Science and Technology*. 2011;2(4):166-169.
  23. Boja C, Pocatilu P, Zamfiroiu A. Secure SMS communications for M-learning services. In Proceedings of the 5th European conference on European computing conference, ECC. 2011;11: 480-484.
  24. Arif ASM, Mahamud A, Islam R. An enhanced static data compression scheme of Bengali short message. arXiv preprint arXiv:0909.0247; 2009.
  25. Nanda AK. SMS security using ntru cryptosystem for m-commerce. Research Scholar, CSE Department National Institute of Technology; 2012.
  26. Goldwasser S, Bellare M. Lecture notes on cryptography summer course 'cryptography and computer security'; 1999.
  27. Alanazi H, Zaidan BB, Zaidan AA, Jalab HA, Shabbir M, Al-Nabhani Y. New comparative study between DES, 3DES and AES within nine factors. arXiv preprint arXiv:1003.4085; 2010.
  28. Singh A, Maheshwari S, Verma S, Dekar R. Peer to peer secure communication in mobile environment: A novel approach. *International Journal of Computer Applications*. 2012;52(9):24-29.
  29. Rogaway P. Evaluation of some blockcipher modes of operation. Cryptography Research and Evaluation Committees (CRYPTREC) for the Government of Japan; 2011.
  30. Bellare M, Kilian J, Rogaway P. The security of the cipher block chaining message authentication code. *Journal of Computer and System Sciences*. 2000; 61(3):362-399.
  31. Klíma V, Rosa T. Strengthened encryption in the CBC mode. *IACR Cryptol. ePrint Arch*. 2002;61.
  32. Deepakumara J, Heys HM, Venkatesan R. FPGA implementation of MD5 hash algorithm. In Canadian Conference on Electrical and Computer Engineering 2001. Conference Proceedings (Cat. No. 01TH8555). 2001;2:919-924. IEEE.
  33. Grundmanis R. How to crack MD5 algorithm using advanced brute force. *Applied Information and Communication Technologies*. 2010;256-262.
  34. Wikipedia. Block cipher mode of operation. Retrieved from Wikipedia; 2019. Available: [https://en.wikipedia.org/wiki/Block\\_cipher\\_mode\\_of\\_operation#Cipher\\_feedback\\_\(CFB\)](https://en.wikipedia.org/wiki/Block_cipher_mode_of_operation#Cipher_feedback_(CFB))
  35. Powell M. Evaluating lossless compression methods. In New Zealand Computer Science Research Students' Conf., Canterbury. 2001;35-41.
  36. Affandi A. The application of text compression to short message service using huffman table. *Jurnal Generic*. 2013;6(1):19-24.

37. Burr WE. Selecting the advanced encryption standard. IEEE Security & Privacy. 2003;1(2):43-52.
38. Idrus RM. Mobile learning in distance education: SMS application in a physics course. Mobile learning: Malaysian initiatives and research findings. Malaysia: Centre for Academic Advancement, Universiti Kebangsaan Malaysia; 2013.
39. Ling R. The sociolinguistics of SMS: An analysis of SMS use by a random sample of Norwegians. In Mobile communications. Springer, London. 2005;335-349.

© 2023 Premadasa; This is an Open Access article distributed under the terms of the Creative Commons Attribution License (<http://creativecommons.org/licenses/by/4.0>), which permits unrestricted use, distribution, and reproduction in any medium, provided the original work is properly cited.

*Peer-review history:*  
*The peer review history for this paper can be accessed here:*  
<https://www.sdiarticle5.com/review-history/102816>