

# Enhancement of Vehicle Dynamics with Application of H Arm at Rear Suspension System

**Kalyan Pavan Kumar<sup>1\*</sup>, Charita Vemula<sup>1</sup> and B. Sai Baba<sup>1</sup>**

<sup>1</sup>Mechanical Engineering, Vasavi College of Engineering, India.

## **Authors' contributions**

*This work was carried out in collaboration among all authors. Author KPK designed the Suspension Geometry of the vehicle and Simulated the results in Lotus software in Detail. Author CV performed the complete analysis on the components of the suspension system in Ansys along with the study of suspension geometry for automobiles. Author BSB study of Manufacturing methods to the components with their reliability and ease of manufacturing and a detailed description about the H-arm suspension system and wrote the first draft of the manuscript. All authors read and approved the final manuscript.*

## **Article Information**

DOI: 10.9734/CJAST/2021/v40i2731525

Editor(s):

(1) Diyuan Li, Central South University, China.

Reviewers:

(1) Jerzy Kisilowski, Kazimierz Pulaski University of Technology and Humanities in Radom, Poland.

(2) Raheel Muzzammel, University of Lahore, Pakistan.

Complete Peer review History: <https://www.sdiarticle4.com/review-history/65958>

**Original Research Article**

**Received 01 August 2021**

**Accepted 03 October 2021**

**Published 11 October 2021**

## **ABSTRACT**

The conventional design and manufacturing of rear suspension system in All terrain Vehicles were Double wishbone, Semi trailing arm, Mcpherson strut and torsion bar but to overcome the adverse effects such as wheel wobbling, Uncontrolled Toe and power losses from transmission. So by introducing a H-arm suspension system at the rear end of the vehicle can improve the performance of the vehicle by keeping it stable and able to sustain all the incoming loads from the ground and provides a comfortable drive and by maintaining a constant Toe which will improve the transmission. The primary objective of the suspension system in the ATV is to maximise the contact between the tires and the road surface, providing good handling and steering stability, evenly distributed weight throughout the vehicle and ensuring riders safety also comfort by absorbing the shocks from the terrain. Ansys solver is used for analysis, lotus shark used for the simulation and the modelling is done by using Solidworks 19. Fabrication of the system was done according to the Design values, run- virtual compliance test is performed for checking the vehicle dynamics.

\*Corresponding author: E-mail: [charita.vemula@gmail.com](mailto:charita.vemula@gmail.com);

*Keywords: Suspension system; design; analysis; fabrication; stability.*

## 1. INTRODUCTION

A suspension system allows the vehicle to travel over rough surfaces with minimum up-and-down body movement. It also allows your vehicle to corner with minimum roll or sway, stop with a minimum of brake dive, and accelerate with a minimum of acceleration squat. It consists of arms, damper, spring, joints, tyre, knuckle and hub. A good suspension system handles the roughest of terrain and endures extreme force conditions without affecting the vehicle's stability and at the same time provides a smooth ride to the passengers. Independent suspension system is a system that allows both the wheels on an axle to move independently of each other. When an independent suspension system is used, the bump mainly affects only the contacted wheel; this provides better comfort, safety and stability to the vehicle and passengers.

Functions of Suspension System:

- To prevent the road shocks from being transmitted to the vehicle frame.
- To preserve the stability of the vehicle in pitching and rolling.
- To provide good road handling while driving, cornering and braking.
- Resist roll of the chassis.

Objectives of Suspension System for an All-Terrain Vehicle.

- Large suspension travel.
- Adjustability, to tune the suspension.
- Good ground clearance.
- Simple and light-weight construction.

The H-arm suspension system is used in the rear because of its single degree of freedom, so the toe is restricted and its minimum camber variations. Two linkages in the lateral direction in an H-arm suspension system help in handling large amounts of lateral loads which are induced during cornering as one of the linkages will be in compression and the other in tension. When H-frame is paired with a lateral link, it is considered equivalent to a double wishbone suspension system, four bar linkages are formed and the articulation of each linkage is controlled by changing lengths and positions of the pivot points. The forces generated due to weight transfer during acceleration are taken by the H-frame as the frame is mounted inclining

backwards. This suspension system is more stable and the camber variations are minimal, the toe angle is constant due to its linkage restrictions.

## 2. DESIGNING PHASE OF H-ARM SUSPENSION SYSTEM

### 2.1 Selection of Type of the Suspension System

Requirements for the rear suspension system of an ATV.

- To bear greater loads due to rear placement of the Engine, Gearbox and live-axles.
- Should not allow great camber changes.
- Must not allow toe changes.
- Must be independent.
- Must not allow axle-plunge out.

Keeping the above as a major priority, H-arm Suspension system satisfies the requirements over all other systems with the required wheel travel and safety of the components with high factor of safety.

### 2.2 H-Arm Suspension Geometry

H-arm suspension consists of H-arm/frame and also contains one link in lateral direction which is used to carry lateral load and also controls camber through suspension travel. This system provides the required camber and toe control.

Components used in the H-Arm Suspension System:

- H-arm
- Lateral Link
- Upright
- Hub
- Shock Absorber
- H- arm system mounts on the chassis

### 2.3 Steps for Designing the Suspension System

The basic criterion to achieve better handling was to have camber gain in roll. In other words, as the car corners, the goal is to gain negative camber at the outer wheels and to gain positive camber at the inner wheels of the vehicle. By providing sufficient camber gain the wheels

remain vertical to the ground even when the body rolls, which provides better grip while cornering. Also, the roll centre of the rear suspension was kept higher than the roll centre in front to decrease over steering of the vehicle. The roll centre has a significant impact on a suspension's steering response; moreover, there is a direct correlation between roll centre location and over steer, understeer, or neutral steer suspension behaviour depicted below.

To start with the suspension designs firstly the vehicle parameters such as wheel track, wheel base were defined according to the rules specified by SAE BAJA which states that "Maximum dimensions of vehicle should be 64 inches width".

### 2.3.1 Considerations

- Track width and the size of the tyre and wheel combination i.e. the width of the tyre in-order to get the centre of the tyre as in Lotus software the hardpoints are considered as the centre points or so of the components.

- The rear engine cabin of the vehicle in order to get the mounting points of the suspension.
- Ground clearance.
- Rim offset (if any).
- Space constraints of the rim.
- Wheel Base.
- Rim and Tyre information like diameter, thickness(width).
- Shock Absorber eye-to-eye length.
- Motion Ratio.

While designing in the Lotus software [1,2] make sure that the hardpoints placed in 3D space will not clash with any of the components in the real scenario.

The track width was kept smaller to aid in maneuverability. The wheelbase was kept minimal to decrease the turning radius. To maximize the obstacle avoidance, a ground clearance of 14 inches from the ground to the lowermost member on the chassis was chosen. Recessional wheel travel is also provided which accounts for the longitudinal forces that arise during the vehicle approaches a bump.

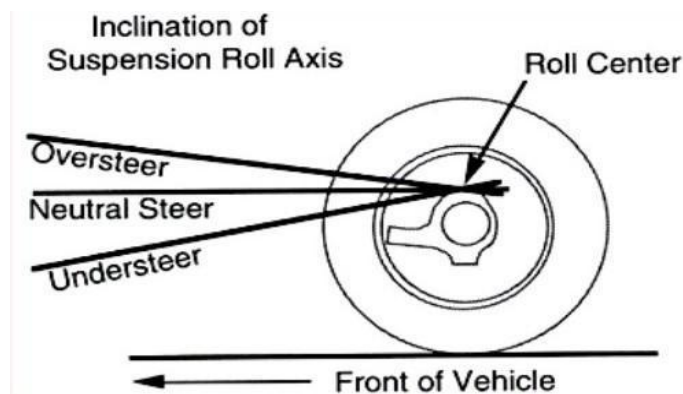

Fig. 1. Effect of roll axis

Table 1. Desired rear suspension parameters for designing the system for the required tracks

Parameters	Value
Bump Travel (in)	4.6
Droop Travel (in)	1.4
Ground Clearance (in)	14
Track Width (in)	50
Static Camber (°)	0
Toe (°)	0
Stiffness(k) (N/mm)	Variable
Sprung Mass (kg)	99.4
Unsprung mass (kg)	50.8
Total weight with driver (kg)	250 (approx..)

Note: The above-mentioned values may change as these are the target values to be achieved after the simulation using Lotus software in-order to get best suspension geometry parameters

### 2.3.2 Roll centre and its position

Roll centre should be placed at an optimum position so that the effect of the jacking force is less and roll over chances are also less, thereby the stability of the vehicle increases.

## 3. SIMULATION PHASE

### 3.1 Introduction to Lotus Shark

#### 3.1.1 What is lotus suspension analysis?

LSA is a design and analysis tool that can be used for both the initial layout of a vehicle suspension's hardpoints, and also the design and orientation of suspension bushes for the tuning of the complaint behaviour. Models are created and modified through a 3d-viewing environment. This allows hard points and bushes to be 'dragged' on screen and graphical/numerical results updated in 'real time'. A template-based approach to the modelling allows users to create their own suspension models, supplementing the 'standard' suspension templates provided.

#### 3.1.2 Normal uses of lotus suspension analysis

LSA is used by both designers and analysts alike for the layout of the suspension hardpoint positions, in order that the required kinematic behaviour is achieved. Any number of results can be displayed graphically, (e.g. Camber angle, Toe angle), against bump motion, roll motion or steering motion. These results are updated in 'real time' as the suspension hard points are moved. The inclusion of compliant bushes to the kinematic model allows the tuning of bush properties to be carried out, to achieve required compliant response for items such as lateral force steer.

#### 3.1.3 Overall concepts

LSA has two main display and analysis modes, 2D and 3D, and it is possible to import a 2D model into 3D. Suspensions can be articulated in bump/rebound, roll, steering and combined bump and steering (3D only) modes. LSA uses templates to identify specific 3D suspension types. These templates define the number of parts, the number of points and connectivity of the parts. A large number of 'standard' templates are included with the installation, whilst users can

create their own or modify existing ones to model kinematic suspension types not catered for. 3D models can be built as corner, axle or full vehicle suspension models. LSA can be used just in Kinematic mode, (i.e. rigid bodies with ball joints), or in compliant mode where the deflection due to bushes is added to the kinematic results on an incremental basis, (note that the compliant module is licensed additionally to the kinematic module). The compliant mode includes modal analysis and forced damped capability.

#### 3.1.4 Coordinate system

The LSA coordinate system is a right-handed system the origin of which must be in front of the car and coincide with the vehicle longitudinal centre line.

Y-axis is across the car track, and the +ve direction being towards the right side when sitting in the car.

X-axis is along the vehicle wheelbase and positive toward the rear of the car.

Z-axis is the vertical height and positive upwards.

When inputting suspension hardpoint data you must ensure that all coordinates are consistent with the origin you have selected and be aware that all suspension hardpoint output generated by LSA will be relative to that origin. The only restrictions are that the X-Z plane must pass through the centre of the car and the origin must be in front of the car. The coordinate system origin need not be coincident with the ground plane.

#### 3.1.5 Sign convention [3]

**Camber** - Inclination of the wheel plane to the vertical, negative when the wheel leans in at the top.

**King Pin Angle** - Front view angle between the steering axis and the vertical. Positive when the steering axis leans inwards at the top.

**Toe** - Angle between the plane of the wheel and the forward direction, positive if the front of the wheel is "toed in" toward the centre of the car.

**Castor** - Side view angle in between the steering axis and vertical. Positive when the top of the steering axis is inclined toward the rear.

**Steering Lock** - Linear Y-axis displacement of the steering rack. Positive steering lock can produce negative or positive toe depending if the steering rack is in front or behind the steering axis.

The Hard points are placed in the 3D space as the requirement and varied in order to get the required suspension geometry parameters like camber and toe variations with respect to the wheel travel.

**Roll** - Right hand rule applied to the vehicle in positive x-axis. When sitting in the car roll to the left is positive.

The following figure will give the details of the camber and toe variation with respect to the wheel travel (bump + droop) (Fig 3).

**4.2 Simulation for H-Arm Suspension System**

All the required suspension parameters are given as input to the lotus simulation software according to the parameters given above.

[3,1] The test was completely successful and checked where there were no errors, no linkage breakdowns or scenarios where it couldn't pass through. Therefore, after simulation the design of suspension is deemed to be fit for usage in All-terrain vehicles.

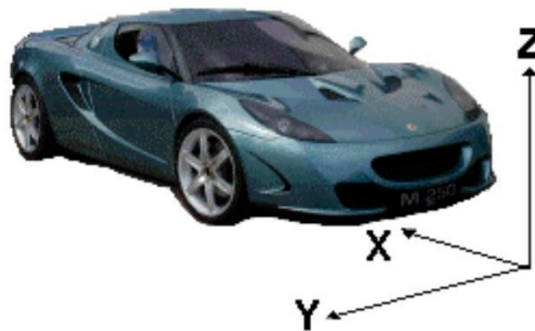

**Fig. 2. LSA coordinate system**

**Table 2. Inputs given to the software**

	Edit Value	
Bump Travel (mm)	116.840	
Rebound Travel (mm)	35.560	
Bump/Rebound Increment (mm)	20.000	
Roll Angle (deg)	2.500	
Roll Increment (deg)	0.500	
Steer Travel (mm)	22.300	
Steer Increment (mm)	3.000	
Wheelbase (mm)	1430.000	
C of G Height (mm)	482.600	
Braking on Front (%)	60.000	
Drive on Front (%)	0.000	
Weight on Front (%)	40.000	
Front Brake Type (1/2 inboard/outboard)	2	
Rear Brake Type (1/2 inboard/outboard)	2	
Total Sprung Weight (kg)	150.0000	

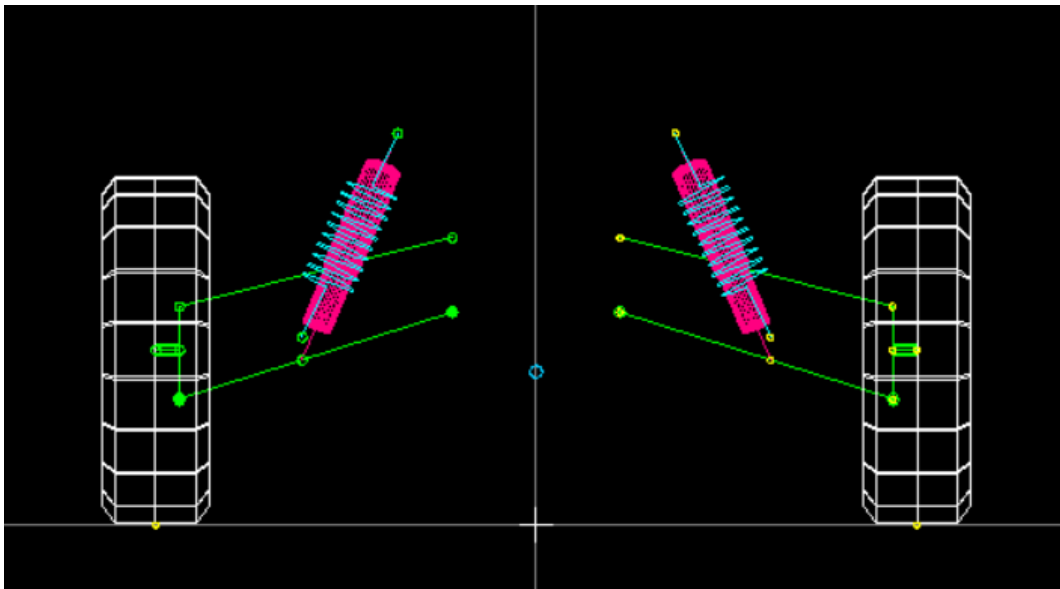

Fig. 3. Link clash is observed according to the required geometry

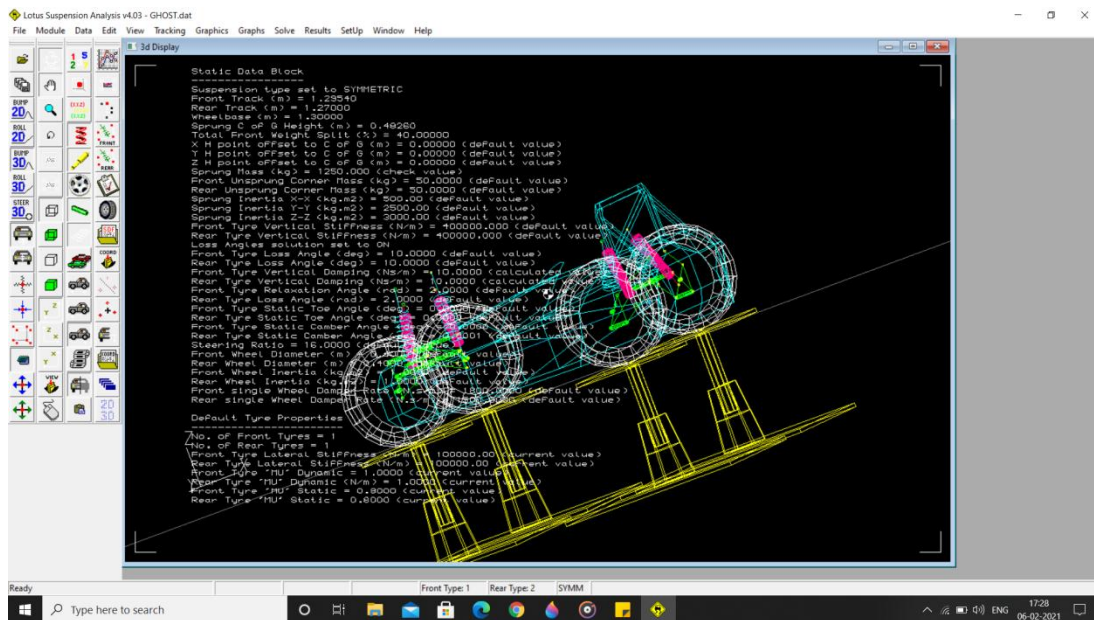

Fig. 4. Run virtual compliance test starting

### 3.3 Selection of Shock

Studying about the requirement of the spring-damper system for an All-Terrain Vehicle, it was concluded that the variable spring stiffness would be more helpful to the vehicle in many ways i.e. the ride comfort can be varied as per the requirement to ensure a safe drive. So, instead of going for coil-overs, which have fixed spring stiffness, FOX FLOAT 3-factory series was finalized to be used for the vehicle in both front and rear suspension.

FOX FLOAT (FOX Load Optimizing Air Technology) 3 air shocks are high-performance shock absorbers that use air as springs, instead of heavy steel coil springs or expensive titanium coil springs. Underneath that air sleeve is a high-performance, velocity-sensitive, shimmed damping system. FLOAT 3 air shock dampers contain high pressure nitrogen gas and FOX high viscosity index shock oil separated by an Internal Floating Piston system. This helps to ensure consistent, fade-free damping in most riding conditions.



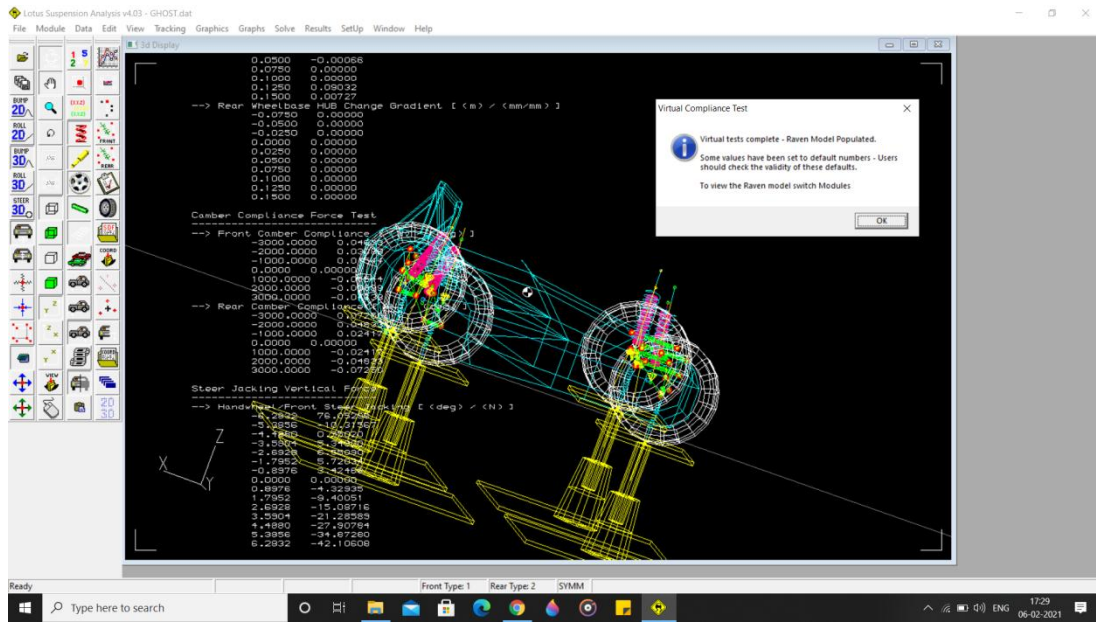

Fig 5. Run virtual compliance test successfully completed

Table 3. Fox float 3 characteristics

Parameter	Value
Eye-to-Eye length (in)	16.2
Weight (kg)	1.5 each piece
Stroke length (in)	6.2
Motion Ratio (for mounting)	0.6

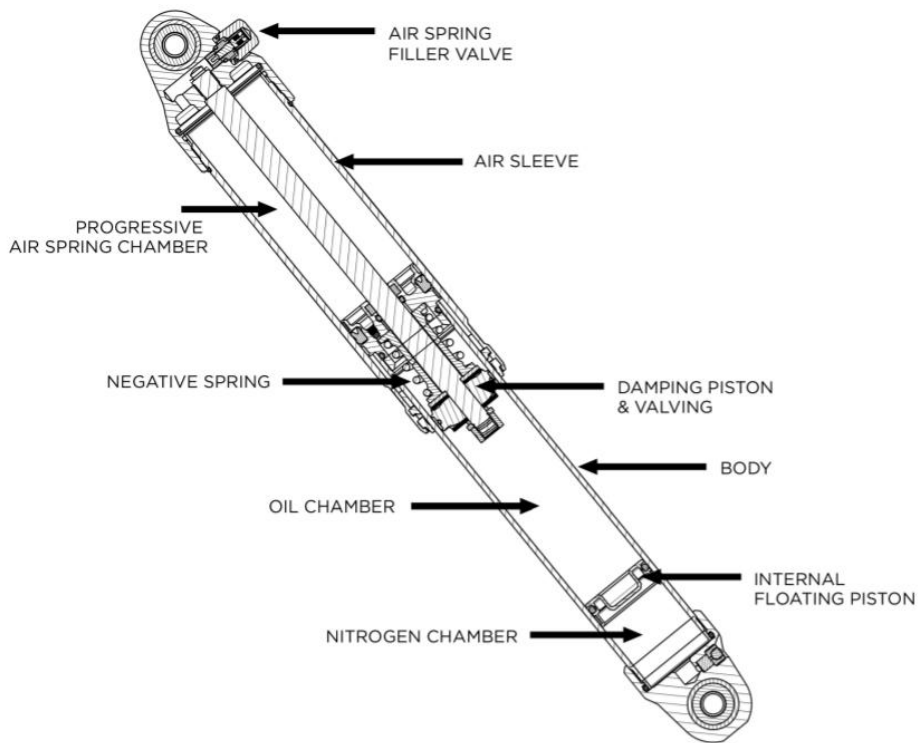

Fig. 6. FOX FLOAT 3

## 4. MODELLING OF SUSPENSION SYSTEM

### 4.1 Introduction to SOLIDWORKS

All components are designed using SOLIDWORKS software which is a flexible and powerful integrated solution that helps us deliver better products faster and more efficiently. SOLIDWORKS enables us to perform simulations and analysis on the parts created. Simulations like thermal, flow, frequency, etc., can be done and the results can be used for optimizing the system.

Presently Solidworks is used in many industries like Automotive, Aerospace, Communications, Energy, Mining, Construction, etc.

### 4.2 H-Arm Suspension System Components

#### 4.2.1 Hub

To design a hub, firstly the lengths are taken from the Lotus Software in order to satisfy the parameters and also the combination of the hub and upright. Then the rim offset and the PCD of the rim is to be considered so as to bolt the hub to the rim and also the bearing dimensions which are to be used in order to combine the hub and upright. The following design of the hub is made

in support of an inboard braking system [4]. The thickness of the hub depends on the factor of safety and the type of the material used for manufacturing.

#### 4.2.1.1 Modelling Procedure

- Open Solidworks>new>part.
- Sketch>Top plane>circle1>diameter1>Extruded Boss>distance1.
- Select surface>circle2>diameter2>Extruded Boss>distance2.
- Reference Plane>surface>distance>circle3>diameter 3>ExtrudedBoss>distance3.
- Select surface>semi-circle 1>radius1>arc>radius2>circular pattern>number>ok.
- Circle4>diameter4>circular pattern>number>Extruded Boss>distance4.
- Select surface>circle5>diameter5>Extruded cut>through all.
- ReferencePlane>surface>distance>line>tri angle>smartdimension>circular pattern>number>ok.
- Fillet>edge1>ok.
- Fillet>edge2>ok.

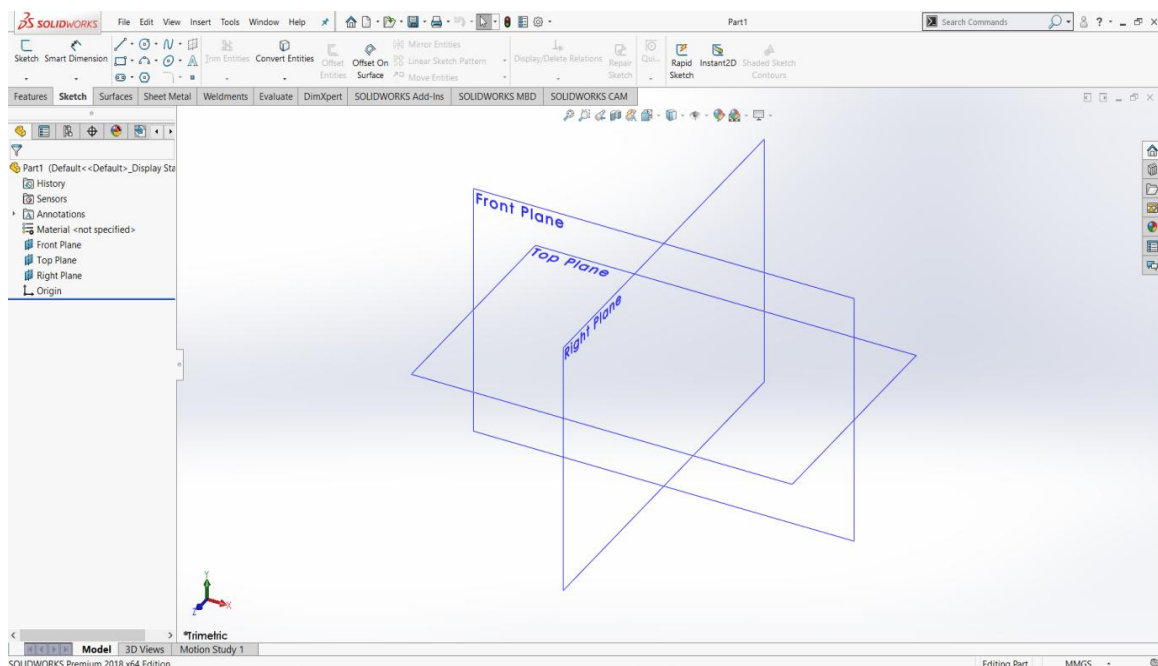
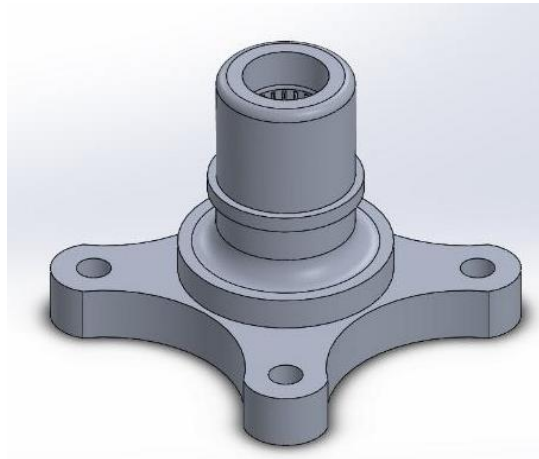

Fig. 7. Interface of the solidworks





**Fig. 8. Hub**

#### 4.2.2 Upright

To design an upright, firstly the lengths are taken from the Lotus Software in order to satisfy the parameters and also the combination of the hub and upright. The bearing dimensions are to be considered in order to have a proper assembly between the hub and upright and also the thickness of the upright should satisfy the region where the h-arm and the lateral link are bolted to the upright. The thickness of the upright also depends on the factor of safety and the type material used for manufacturing.

##### 4.2.2.1 Modelling Procedure

- Open Solidworks>new>part.

- Sketch>Front plane>profile>smart dimension>Extruded Boss>distance1.
- Select surface >rectangle>smart dimension>Extruded cut>through all.
- Select surface>arc1>arc2>radius>line>smart dimension>Extruded cut>throughall.
- Select surface>circle1>diameter1>Extruded cut>blind>distance1.
- Select surface>circle 2>diameter2>Extruded cut>blind>distance2.
- Select surface>circle3>circle 4>diameter3>Extruded cut>through all.
- Fillet>edges>ok.

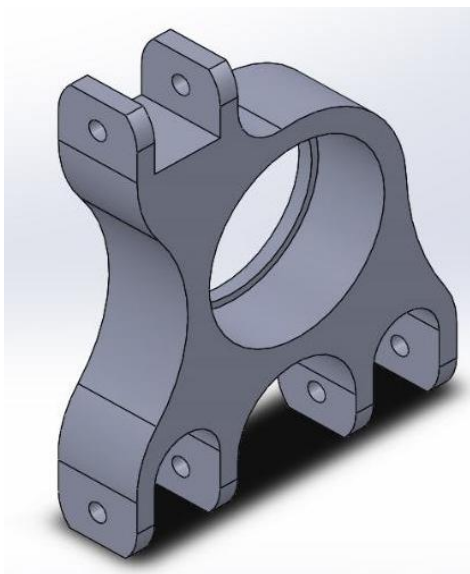

**Fig. 9. Upright**

### 4.2.3 H-Arm

To design an H-arm, firstly the lengths are to be taken from the Lotus software so that the arms do satisfy the real-life scenario. The dimensions of the pipes should be based upon the bending stiffness and bending strength of a pipe as per the rules of the SAE BAJA event. To design a H-arm, weldments are to be used so before designing, a weldment file is to be created as per the required dimensions. Motion ratio is to be considered in order to mount the shock absorbers i.e. to design the clamps on the H-arm.

#### 4.2.3.1 Modelling Procedure

##### Process 1

- Open Solidworks > new > part.
- Sketch > front plane > circle1 > circle2 > smart dimensions > exit sketch.
- Select sketch > file > save as > file type – lib feat part > location – desktop.
- Now replace the saved file in the weldments files of the Solidworks administrator file.

##### Process 2

- Open Solidworks > new > part.
- Sketch > top plane > line1 > line 2 > line3 > line4 > line5 > line6 > line7 > smart dimensions > weldments > group1 > group2 > group3 > ok.

- Reference plane1 > arc1 > line8 > line9 > line10 > line11 > arc2 > circle1> Extruded boss> blind > distance1.
- Reference plane 2> mirror (previous extruded boss) > ok.
- Reference plane3> circle2 > circle3 > smart dimensions > extruded boss> upto next surface > ok.

Repeat the above step for 3 more times.

### 4.2.4 Lateral link

To design a lateral link, firstly the lengths are to be taken from the Lotus software so that the link does satisfy the real-life scenario. The dimensions of the pipe should be based upon the bending stiffness and bending strength of a pipe as per the rules of the SAE BAJA event. To design a lateral link, weldments are to be used so before designing, a weldment file is to be created as per the required dimensions.

Process 1 is the same as that of the H-Arm.

##### Process 2

- Open Solidworks > new > part.
- Sketch > top plane > line1 > line2 > line3 > weldments > group1 > group2 > ok.
- Reference plane1 > circle1> circle2> smart dimensions > extruded boss> upto next surface > ok.

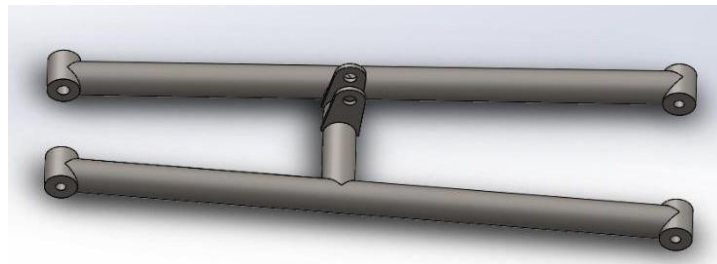

**Fig. 10. H-arm**

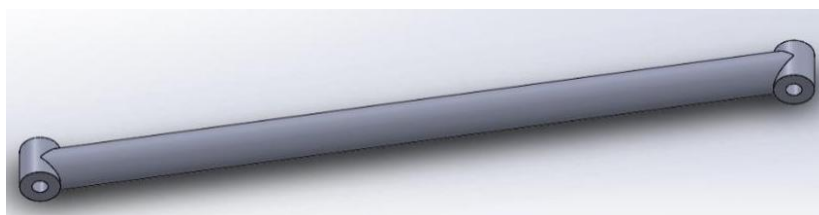

**Fig. 11. Lateral link**

Note: A bearing of 40 mm ID 76 mm OD and 30.2 mm thickness is used. Bearing no. 3208, A double row angular contact ball bearing

## 5. ANALYSIS PHASE

### 5.1 Introduction to ANSYS

Ansys Mechanical finite element analysis software is used to simulate computer models of structures, electronics, or machine components for analyzing strength, toughness, elasticity, temperature distribution, electromagnetism, fluid flow, and other attributes.

ANSYS typically creates the user an opportunity to create a virtual environment to simulate the tests or working conditions of the products before manufacturing the prototypes. This would certainly reduce the cost of producing prototypes and mainly the time.

Now, for analyzing the suspension components we make use of the static structural modal.

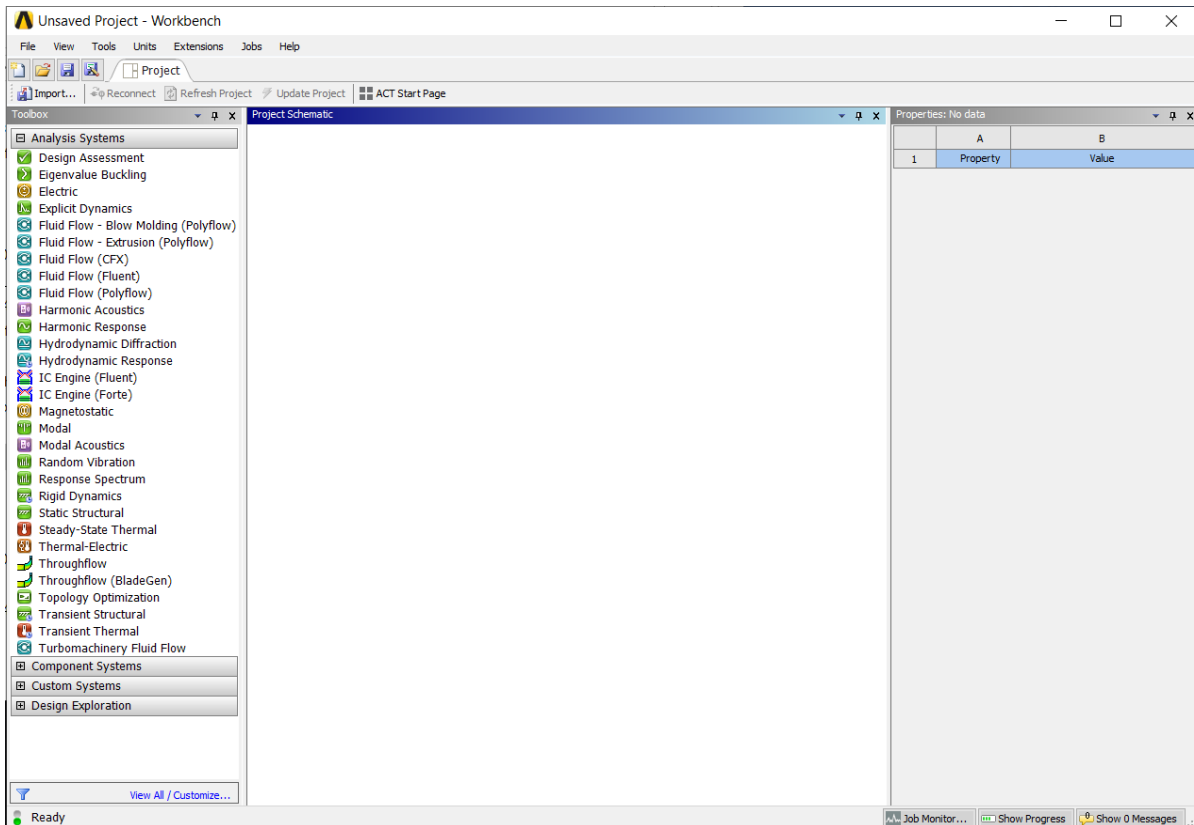

Fig. 12. Ansys start-up window

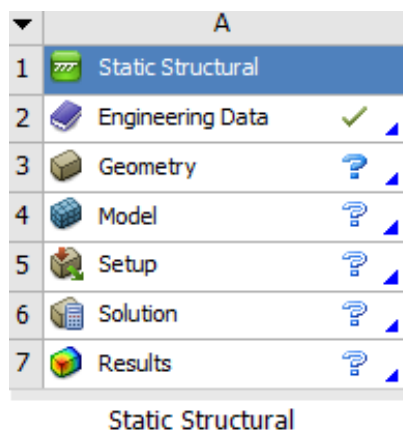

Fig. 13. Static structural modal

Initially, the Ansys solver takes the engineering data to be structural steel and its properties for the analysis of the components. As per the requirement, the material properties are given as input in the engineering data.

Now, the geometry i.e. the designed models of the components are imported either in IGES or PARASOLID format for the analysis as these two formats are familiar and accurate for the solver.

Now, in model the components are meshed into finite elements so that each element of the component can be analyzed for the given constraints. Then the force and fixed constraints are given to the component and analyzed for detecting any failures with help of the results.

## 5.2 H-arm Suspension Components

### 5.2.1 H-Arm

[5,6] AISI 4130 1in OD 2mm thickness was selected over AISI 1018, AISI 1020, AISI 1080, considering the strength-to-weight ratio in order to make the arm. Loading conditions were considered to be the worst-case scenario in order to have high safety.

After giving the engineering data and importing the part, in the model the component is to be meshed in order to break it down to smaller elements.

First fix the points which will be connected to the chassis as these are the points about which the

wheel travel is observed. Then forces are to be applied as per the following cases

**Assumption:** Weight of the Vehicle = 250 kg

**Case 1:** Weight of the vehicle acting on 1 wheel in static condition.

As rear suspension would be bearing 60% of the total weight and this will be divided into half for 1 wheel.

$F = (250 \cdot 0.6 \cdot 9.81) / 2 = 735.75\text{N}$  acting along the length of the arm.

**Case 2:** Considering the bump case and also when the vehicle lands on 1 wheel, the total weight of the vehicle is to be considered.

$F = 250 \cdot 9.81 = 2452.5\text{N}$  acting at the points connected to the upright and in upward direction vertically.

**Case 3:** Considering the collision of the wheel with another vehicle in the opposite direction that ends up with a force of 2 g.

$F = 250 \cdot 2 \cdot 9.81 = 4905\text{N}$  acting at the points connected to the upright in longitudinal direction of the chassis. At this case the arm might break denoting that the driver is safe as the force isn't being transmitted to the chassis.

Now, in solutions to consider the total deformation, equivalent stress, safety factor.

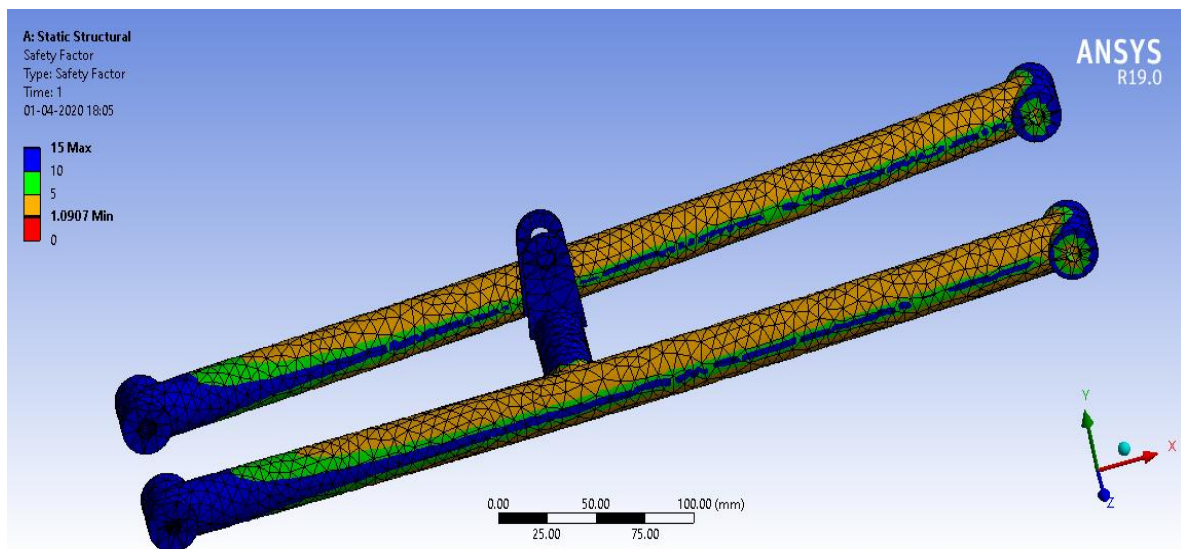

Fig. 14. Safety factor of H-arm

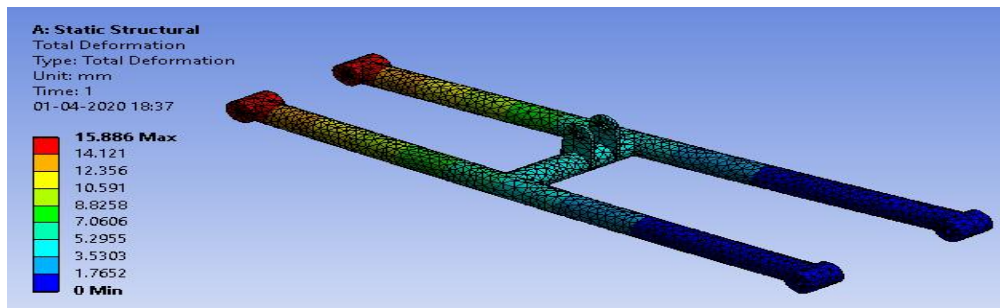

Fig. 15. Deformation of H-Arm

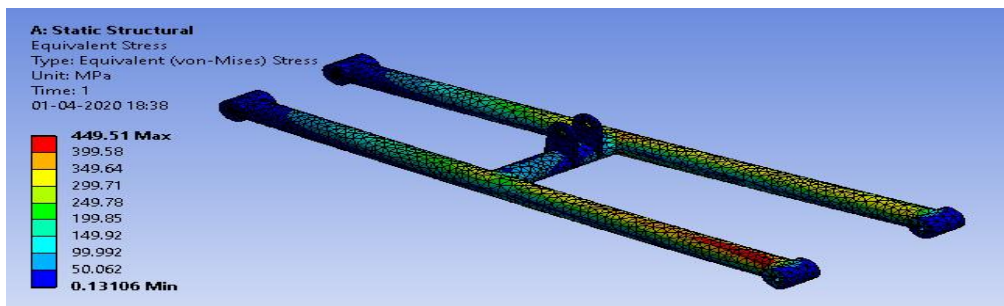

Fig. 16. Equivalent stress of H-Arm

### 5.2.2 Lateral link

AISI 4130 1in OD 1mm thickness was used for its purpose. After giving the engineering data and importing the component, in model the component is meshed properly.

First fix the point that will be connected to chassis, then the forces are applied on the link as follows

**Case 1:** Weight of the vehicle acting on 1 wheel in static condition.

As rear suspension would be bearing 60% of the total weight and this will be divided into half for 1 wheel.

$F = (250 \cdot 0.6 \cdot 9.81) / 2 = 735.75\text{N}$  acting along the length of the link.

**Case 2:** Considering the bump case and also when the vehicle lands on 1 wheel, the total weight of the vehicle is to be considered.

$F = 250 \cdot 9.81 = 2452.5\text{N}$  acting at the points connected to the upright and in upward direction vertically. As most of the force is taken by the h-arm and the shock absorber, the link experiences minimal force in this case.

Now, in solutions to consider the total deformation, equivalent stress, safety factor.

### 5.2.3 Hub

Aluminium 7075 was selected to satisfy the simulation over AL6061, AL6065.

First fix the 4 bolt positions which are used to connect the hub and rim, then apply the force as follows

**Case 1:** Considering the bump and landing on one wheel, the total weight of the vehicle is to be considered.

$F = 250 \cdot 9.81 = 2452.5\text{N}$  acts in the upward direction.

**Case 2:** While cornering, centrifugal force acts outwards of the vehicle while taking a turn at 56kmph with a turning radius of 1.8m. This force acts on the entire hub.

$F = \frac{m \cdot v^2}{r} = \frac{250 \cdot 0.6 \cdot 15.556^2}{1.8 \cdot 2} = 10082.88\text{N}$  (consider for 1 wheel)

**Case 3:** As the axles are fit into the hub via splines, torque from the engine will be applied on the hub by the axles on the splines.

Moment = 544 N/m. (max torque applied at the wheel)

Now, in solutions to consider the total deformation, equivalent stress, safety factor.

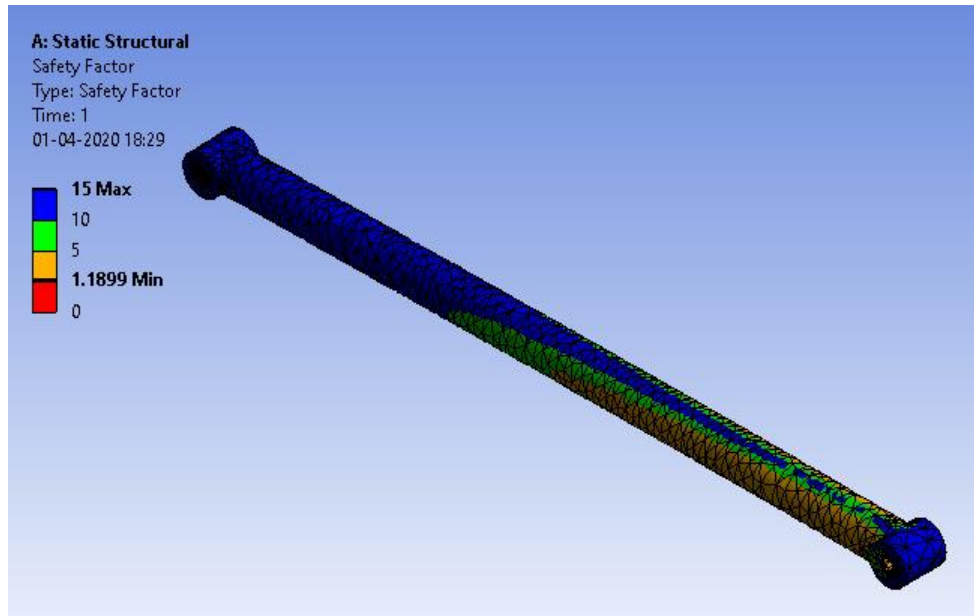

Fig. 17. Safety factor of lateral link

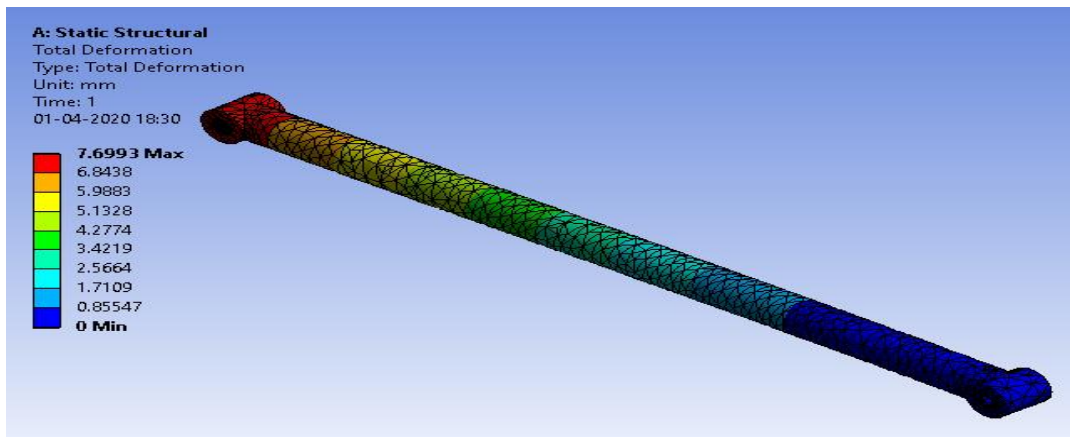

Fig. 18. Deformation of lateral link

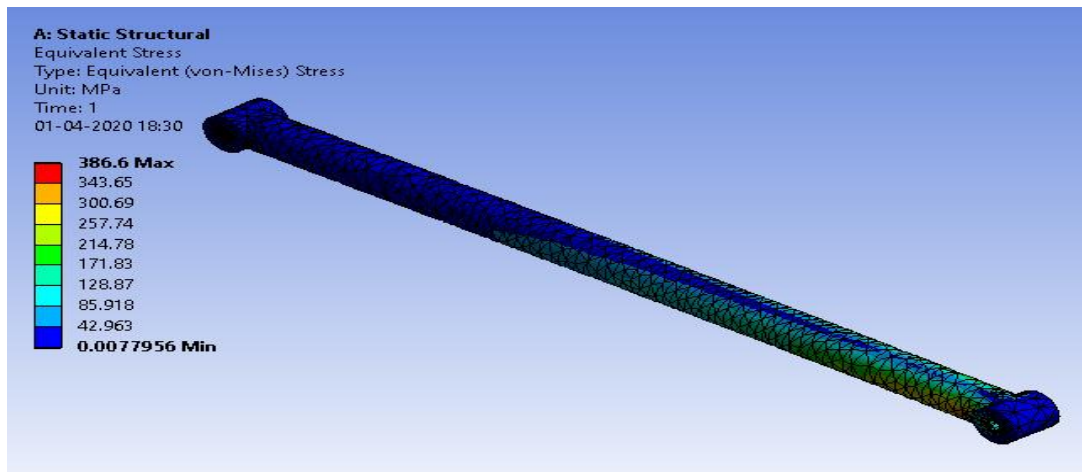

Fig. 19. Equivalent stress of lateral link



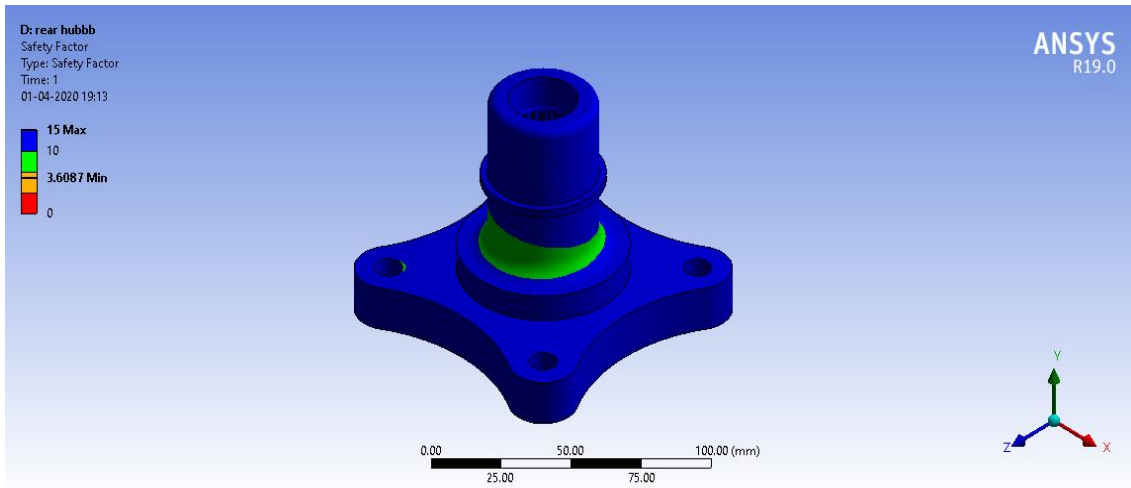

Fig. 20. Safety factor of HUB

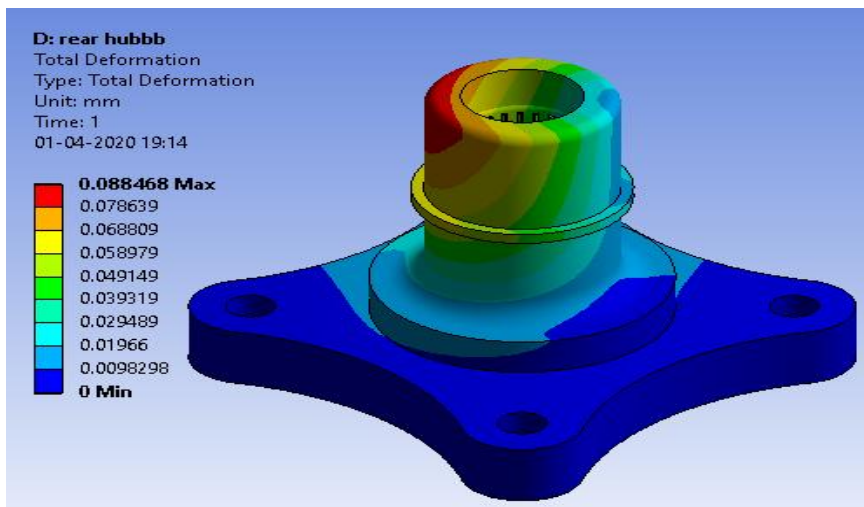

Fig. 21. Deformation of the Hub

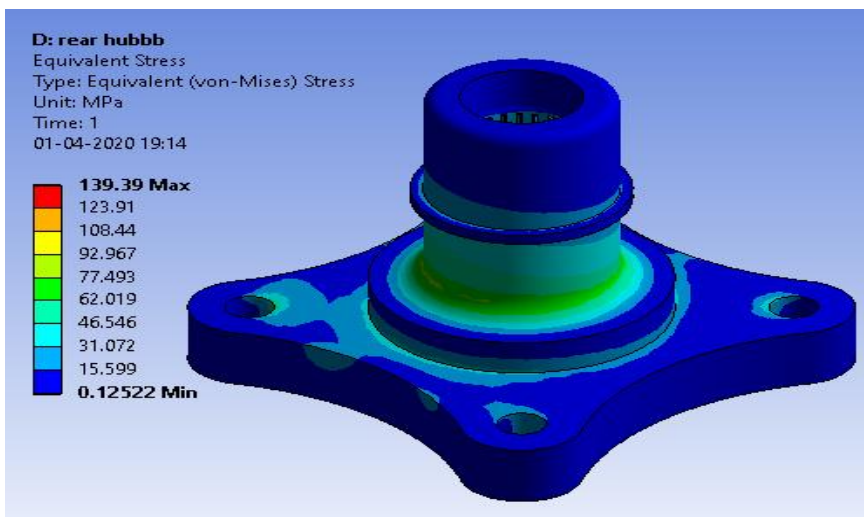

Fig. 22. Equivalent stress of the Hub

### 5.2.4 Upright

Aluminium 6061 was selected to satisfy the load requirements over AL7075, AL6065.

First fix the bearing hole and then apply forces as follows

**Case 1:** Static load of the vehicle on 1 wheel acting along the arms that are connected to the upright.

$$F = 250 \times 0.6 \times 9.81 / 2 = 735.75\text{N}$$

**Case 2:** Considering the bump and landing on one wheel, the total weight of the vehicle is to be considered.

$$F = 250 \times 9.81 = 2452.5\text{N acts in the upward direction.}$$

**Case 3:** Considering the collision of 2 vehicles in opposite directions.

$$F = 250 \times 2 \times 9.81 = 4905\text{N}$$

Now, in solutions to consider the total deformation, equivalent stress, safety factor.

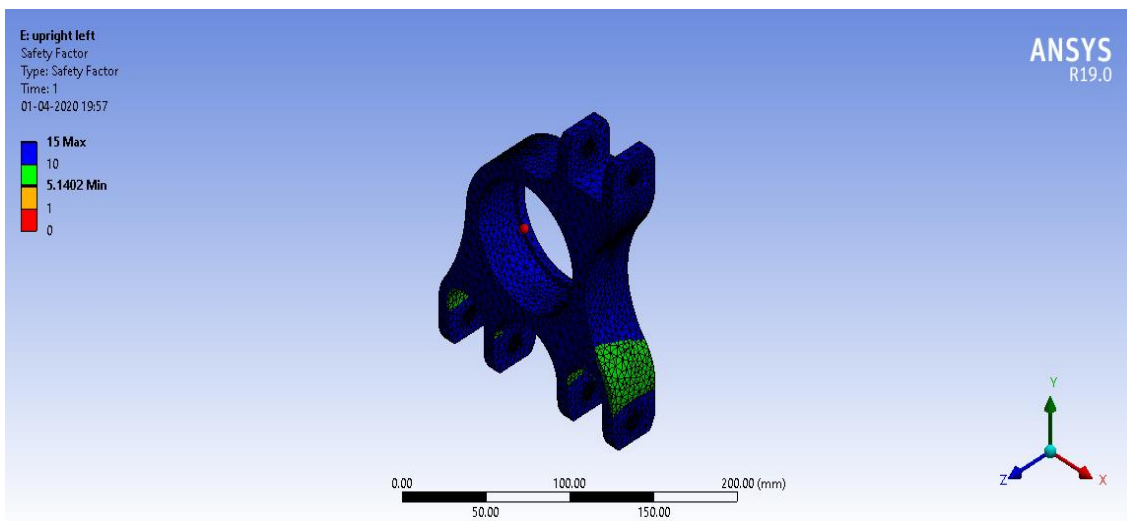

Fig. 23. Safety factor of upright

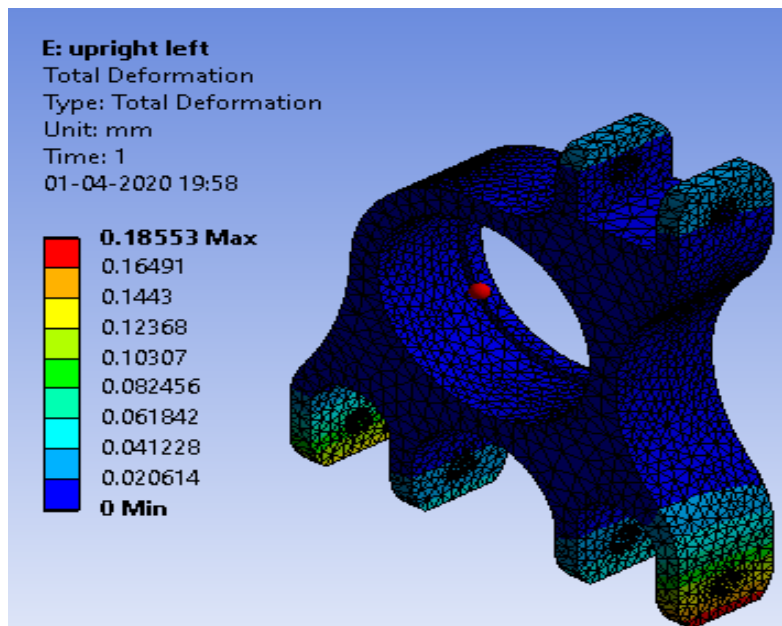

Fig. 24. Deformation of upright

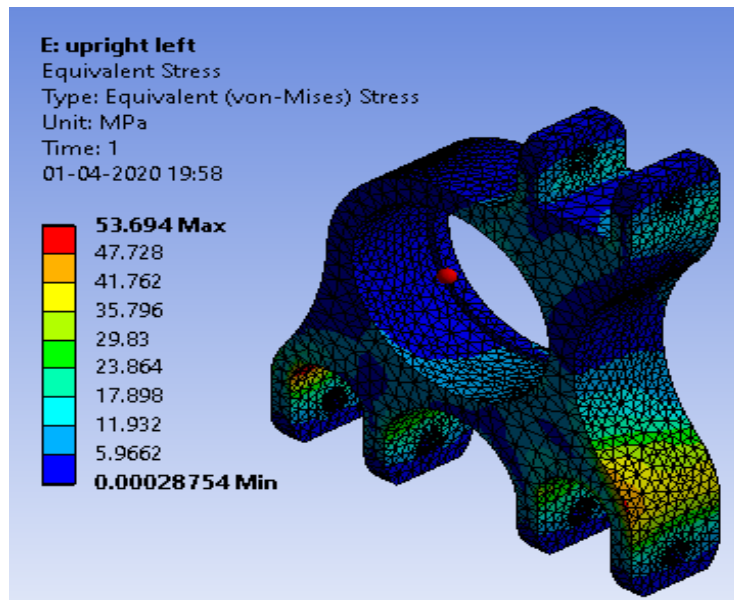

Fig. 25. Equivalent stress of upright

## 6. FABRICATION

### 6.1 Fabrication of H-Arms and Lateral Link

AISI 4130 pipes are cut into the required lengths using an abrasive cutting wheel. Later the pipes are notched using the power tools so that the pipes do connect each without any gap so that the welding of the pipes would be easy.

Once the notching of the pipes is done, the pipes are arranged in the required geometry as per the design, jig are used to hold them in position for welding. Now, the pipes are welded completely using TIG welding process. Once the welding is done, buff the surface for finish and then the rubber bushes are inserted into the pipes which

will be connected to the chassis. These bushes will be helpful for the purpose of damping and weight reduction when compared to a solid bush.

### 6.2 Fabrication of Hubs

Aluminium 7075 is selected for better strength-to-weight ratio. The round bar is turned to required diameters by also making a step so that the bearing sits on the step. Then the holes of the PCD of the rim are made by drilling on a Radial Pillar type drilling machine. The central hole for the splines to be made, first drilling operation is done on the lathe. For splines, CNC gear cutting is done. Then for the bottom part of the hub i.e. the petal portion is made by CNC milling in order to get a perfect and accurate finish as per the design.



Fig. 26. Assembly of H-arm, lateral link, hub and upright



Fig. 27. Hubs

### 6.3 Fabrication of Upright

Aluminium 6061 is selected for the manufacturing of the upright as per the results of the ANSYS. Rectangular block is taken and first it is made of equal thickness on all sides using a surface planar and then by drilling and boring

process the material is removed at the unwanted areas.

Then by milling, the required shape and design is obtained. A step is made by a counter boring as well in order to hold the bearing.



Fig. 28. upright

**Table 4. Values showing the variation of the geometry for the wheel travel**

REAR SUSPENSION - BUMP TRAVEL RHS WHEEL (+ve Y)				
TYPE 2 H-frame Lower, single upper link				
INCREMENTAL GEOMETRY VALUES				
BUMP TRAVEL(mm)	CAMBER ANGLE (deg)	TOE ANGLE (deg)	CASTOR ANGLE (deg)	KINGPIN ANGLE
-40.00	1.0031	0.0000		
-20.00	0.4944	0.0000		
0.00	-0.0001	0.0000		
20.00	-0.4834	0.0000		
40.00	-0.9580	0.0000		
60.00	-1.4264	0.0000		
80.00	-1.8908	0.0000		
100.00	-2.3530	0.0000		
120.00	-2.8151	0.0000		

**Table 5.**

Component	Total Deformation(mm)	Equivalent Stress (MPa)	Safety Factor
H-arm	15.88	449.51	1.09
Lateral Link	7.69	386.6	1.18
Hub	0.08	139.39	3.60
Upright	0.18	53.69	5.14

## 7. RESULTS AND DISCUSSION

### 7.1 Travel v/s Geometry Variation

From the above table it is observed that the camber variation is minimum for the selected suspension system by varying the hardpoints in the lotus software the above result is possible and compatible to the real-life scenario.

### 7.2 Ansys Results

The FEA results are tabulated below and as we can conclude that the design of all the components is safe as the safety factor above.

## 8. CONCLUSION

The results obtained from simulation proves that the tyre remains perpendicular to the ground surface during the cornering of the vehicle, thereby providing better grip with the help of sufficient camber gain.

The team has developed unique designs of each and every component which are built, designed, analyzed, simulated for all kinds of situations making it suitable for the rough-terrain.

This suspension system is suitable for the rough track making the All-Terrain Vehicle strong to the conditions. This project was made successful with the help of our project guide who not only helped us to complete the project but also to excel in the topics of suspension and also be able to use the softwares.

### 8.1 Scope for Future Work

1. By reducing the dimensions of the components like Hub and Upright as per the Lotus software, weight of the components can be reduced.
2. Much effective design with better motion ratios gives out much more wheel travel.
3. Other suspension systems like Semi-Trailing arm can be used to reduce the weight and increase the performance for the same considerations.

## ACKNOWLEDGEMENTS

We would also like to thank our mentor Dr. T. Ramamohan Rao (Head of the Department, Professor, Mechanical engineering, Vasavi college of Engineering) for guiding us through this study.

## COMPETING INTERESTS

Authors have declared that no competing interests exist.

## REFERENCES

1. Albin Vargheese International Journal of Scientific & Engineering Research. 2016;7(3). ISSN:2229-5518.
2. Cherkasov S, Markin G, Akulova A. Suspension kinematics study of the Formula SAE' sports car. Procedia Eng. 2016;150:1280–1286.
3. Improved Vehicle Dynamics with Development in Suspension Geometry, International Journal for Research in Applied Science & Engineering Technology (IJRASET) ISSN: 2321-9653;
4. Kamesh Jagtap, Yogesh Rathod. Suspension system for an all-terrain vehicle: A review. International Journal of Engineering Research and General Science. 2016;4(3).
5. Design And Development of H-Frame with Lateral Link Suspension for an All-Terrain Vehicle - Parag Borse, Vaishnav Mayekar, Nilesh Jain – IRJET. 2017;04.
6. Dynamic Analysis of the Front and Rear Suspension System of an All-Terrain Vehicle - Khan Noor Mohammad, Vatsal Singh, Nihar Ranjan Das, Prajwal Nayak, B.R. Patil – IRJET. 2018;05(03).

IC Value: 45.98; SJ Impact Factor: 7.429.

Available:www.ijraset.com

Sai Rithvick M, Sai Charan Reddy B. Department of Mechanical Engineering, Vasavi College of Engineering, Hyderabad. 2020;8(XI).

© 2021 Kumar et al.; This is an Open Access article distributed under the terms of the Creative Commons Attribution License (<http://creativecommons.org/licenses/by/4.0>), which permits unrestricted use, distribution, and reproduction in any medium, provided the original work is properly cited.

*Peer-review history:*

*The peer review history for this paper can be accessed here:*

<https://www.sdiarticle4.com/review-history/65958>